

Using load cells



Technology
Operating principle
Implementation

Table of Contents

| | |
|--|-----------|
| 1. Introduction..... | 4 |
| 2. Principle of load cells..... | 5 |
| 2.1. About load cells..... | 5 |
| 2.2. Basics of strain gauges..... | 5 |
| 2.3. Wheatstone Bridge circuit..... | 6 |
| 2.4. Application to load cells..... | 6 |
| 3. Type of cell loads..... | 8 |
| 3.1. Single point load cells..... | 8 |
| 3.2. Bending beam load cells..... | 10 |
| 3.3. Shear beam load cells..... | 12 |
| 3.4. S-type load cells..... | 16 |
| 3.5. Column compression load cells..... | 17 |
| 3.6. Low profile compression load cells..... | 20 |
| 3.7. Load pins..... | 23 |
| 4. Load cell specifications..... | 26 |
| 4.1. Legal metrology specifications..... | 26 |
| 4.2. Capacity specifications..... | 28 |
| 4.3. Metrological specifications..... | 29 |
| 4.4. Electrical specifications..... | 30 |
| 4.5. Environmental protection level..... | 31 |
| 5. Designing a weighing system..... | 32 |
| 5.1. Compression versus tension..... | 32 |
| 5.2. Compression mounting kits..... | 33 |
| 5.3. Weighing system performance..... | 38 |
| 5.4. How many load cells?..... | 39 |
| 5.5. Weighing system capabilities..... | 40 |
| 5.6. Determination of the accuracy of the system..... | 41 |
| 5.7. Load cell location..... | 44 |
| 5.8. Load introduction..... | 46 |
| 5.9. Structural integrity..... | 47 |
| 5.10. Lift-off prevention devices..... | 50 |
| 5.11. Stabilisation devices..... | 51 |
| 5.12. Pivoted weighing system..... | 54 |
| 5.13. Piping connections..... | 56 |
| 5.14. Environmental factors..... | 58 |
| 5.15. Calibration..... | 63 |
| 6. Electrical wiring..... | 66 |
| 6.1. General considerations..... | 66 |
| 6.2. 4-wire/6-wire load cells..... | 66 |
| 6.3. Multiple load cells connection..... | 67 |
| 6.4. Cable extension..... | 68 |
| 6.5. Grounding and shielding..... | 68 |
| 7. Load cell troubleshooting..... | 69 |
| 7.1. In general..... | 69 |
| 7.2. Load cell test procedure..... | 70 |
| 8. Appendices..... | 73 |
| 8.1. DOs & DON'Ts of load cells..... | 73 |
| 8.2. Protection according to EN60529..... | 74 |
| 8.3. Protection class IP69K according to DIN40050..... | 74 |
| 8.4. Corrosion resistance chart..... | 75 |
| 8.5. Safety instructions..... | 76 |
| Notes..... | 77 |

1. Introduction

The purpose of this guide is to give you an overview of different types of load cells and assist you in designing the most efficient and effective weighing system for your specific requirements.

Load cells are designed to sense force or weight under a wide range of adverse conditions; they are not only the most essential part of an electronic weighing system, but also the most vulnerable.

In order to get the most benefit from a load cell, the user must have a thorough understanding of the technology, construction and operation of this unique device. In addition, the user must be able to select the load cell suited to the application in hand and maintain the load cell throughout its lifetime.

Load cell selection, for trouble free operation, mainly involves choosing the right capacity, accuracy class and environmental protection. It should also be recognised that a particular measuring principle might offer distinct advantages in terms of overload capabilities or ease of mounting.

If, at any time during the designing stages of your weighing system, you have any questions, please feel free to call us for assistance. At SCAIME, we're committed to providing you exactly with what you need, when you need it.

Symbols used in this Manual

The following symbols may be used in this manual to highlight certain parts of the text:



- **Warns of a potentially dangerous situation:** failure to comply with instructions could lead to property damage and/or physical injury.



- **Indicates useful information:** Means that advice or important information about the product or its handling is being given.

2. Principle of load cells

2.1. About load cells

Load cells measure a mechanical force and provide a voltage proportional to that force.

A load cell measures a mass between zero and its stated capacity. This mass is expressed in weight units (grams, kilograms or tonnes). The accuracy of the load cell is generally stated as a percentage of the overall capacity. For example, if a 100kg load cell has an overall accuracy of $\pm 0.03\%$, then that load cell will measure weight from zero to 100kg to a worst-case accuracy of ± 30 grams. This applies whether it is weighing a load of 5kg or 95kg.

A load cell technical datasheet will provide other important information about that load cell:

- **Stated capacity:** The overall capacity of the load cell.
- **Overload:** The maximum percentage of full load that the load cell can handle before damage occurs.
- **Accuracy:** This may be expressed in terms of linearity, hysteresis, repeatability and creep. These figures are all expressed as a percentage of the overall capacity of the load cell.
- **Sensitivity:** The sensitivity of the load cell determines the actual voltage output you will get when you place the full load on the load cell. These figures are all expressed in mV/V.
- **Thermal sensitivity:** This indicates how much the output will change with a change in temperature. It is usually expressed in percent of full load/ $^{\circ}\text{C}$.

2.2. Basics of strain gauges

2.2.1. What is a strain gauge (deformation)?

A strain gauge is a device which translates the deformation on a part into a change in electrical resistance, and in a manner proportional to that deformation. The most common strain gauge consists of a very thin wire, or foil element, arranged as a grid such that linear changes in electrical resistance appear when stress is applied in a specific direction, generally with a base resistance between 350Ω and 1000Ω .

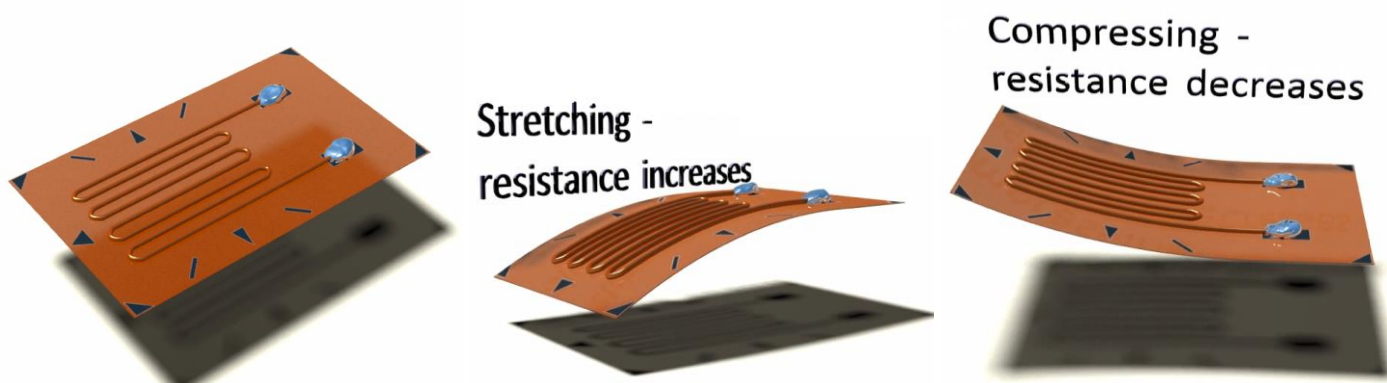

Strain gauges are able to measure small deformations and are actually only used in the elastic range. Deformation or "stretching" is defined as follows:

$$e = \frac{\Delta l}{l_0}$$

With:

- l_0 being the initial gauge length
- Δl being the variation in length when a load is applied

This relative "stretching" is considered as the deformation. As the deformation values are very low, they are expressed as $\mu def = e \times 10^6$

2.2.2. Gauge factor

Each strain gauge has a different sensitivity to strain and which is expressed quantitatively by the gauge factor. The gauge factor is defined as the ratio of the fractional change in electrical resistance to the fractional change in length (deformation). The gauge factor for metal strain gauges is approximately 2.

2.2.3. Deformation and change in resistance

Values for deformation measurements are in the range of a few hundred μdef .

For example, if a strain of **500 μdef** is applied, a strain gauge with a gauge factor of 2 will indicate a change in resistance of only: **$2 \times (500 \cdot 10^{-6}) = 0.1\%$**

For a typical gauge with a **350 Ω** resistance, this represents a change of only **0.35 Ω** which cannot be accurately measured with a standard ohmmeter. A cheap and very precise device must be found to measure this small change in resistance.

2.3. Wheatstone Bridge circuit

The best way to measure small changes in resistance is to use a Wheatstone bridge. A Wheatstone bridge is a configuration of four resistors with a known voltage applied as follows:

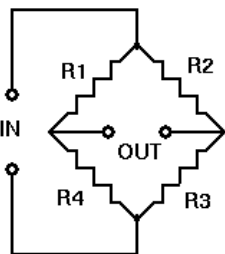

V_{IN} is a known constant voltage, and V_{OUT} is the resulting measured voltage. The relation between V_{IN} and V_{OUT} is given by the equation:

$$V_{\text{OUT}} = V_{\text{IN}} \times \left(\frac{R_1}{R_1 + R_4} - \frac{R_2}{R_2 + R_3} \right)$$

By replacing one of the resistors of a Wheatstone bridge with a strain gauge, we can easily measure the change in V_{OUT} and use it to assess the applied force

2.4. Application to load cells

A load cell with strain gauges is a metal bar, usually made of aluminium or steel, that has been machined so that certain areas are highly stressed when a force is applied to them.

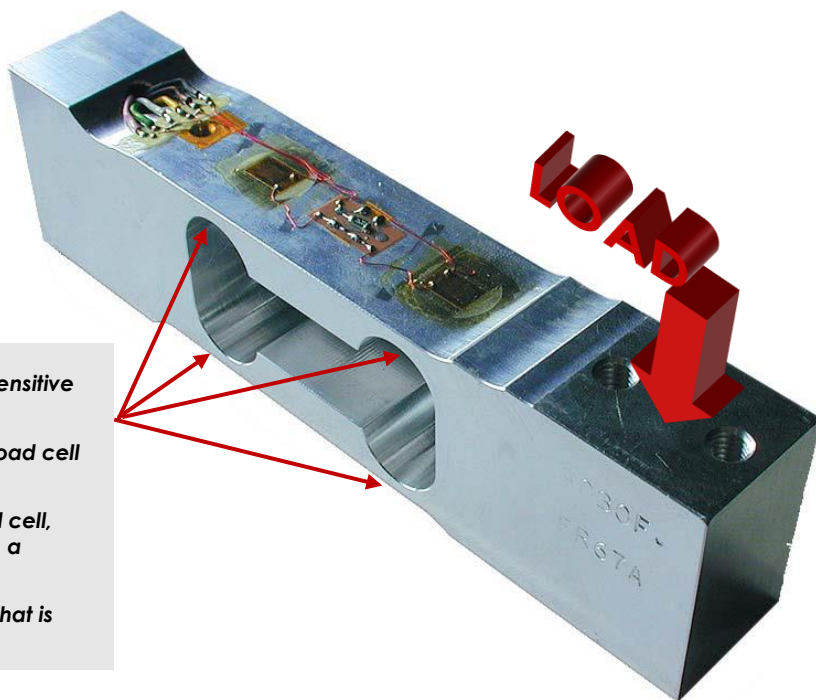

- The strain gauges are attached to places sensitive to deformation
- When the load is applied, the body of the load cell deforms.
- With the strain gauges attached to the load cell, any small movement or stretching results in a change in resistance
- This change produces an electrical signal that is proportional to the load.

The load cell capacities can range from a **few grams to hundreds of tonnes**. The metal piece is machined so that it remains in the elastic range of the material for a deformation equivalent to the load cell's overload capacity.

The relationship between strain and change in resistance is almost perfectly linear. Accuracies between $\pm 0.01\%$ and $\pm 0.02\%$ are not uncommon for a high accuracy load cell.

The strain gauges, usually four or a multiple of four, are connected into a Wheatstone bridge configuration as follows:

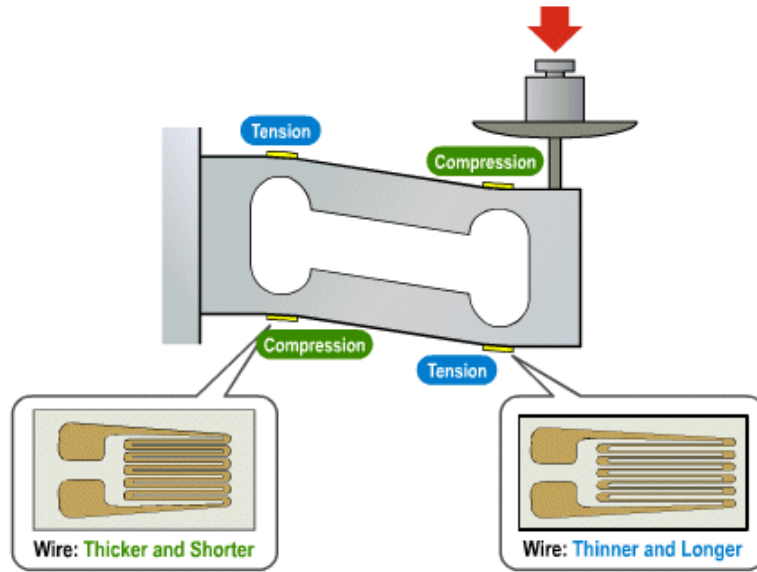

The excitation voltage of the load cells is in the range of 3 to 15 Volts. The signal output from the load cell depends on the load cell itself, but is usually in the range of 0 to 50 mV.

The signal output of the load cells is expressed in millivolts per Volt (mV/V). What this means is that for every excitation volt applied to the load cell, it will output so many millivolts at full scale. This value is called the load cell's sensitivity. The typical sensitivity ranges from 1mV/V to 3 mV/V.

In this example:

- A load cell has a capacity of 2kg and a sensitivity of 2mV/V.
- The weight indicator has an excitation voltage of 5V.

The output signal when a 2kg weight is applied on the load cell is 10mV.

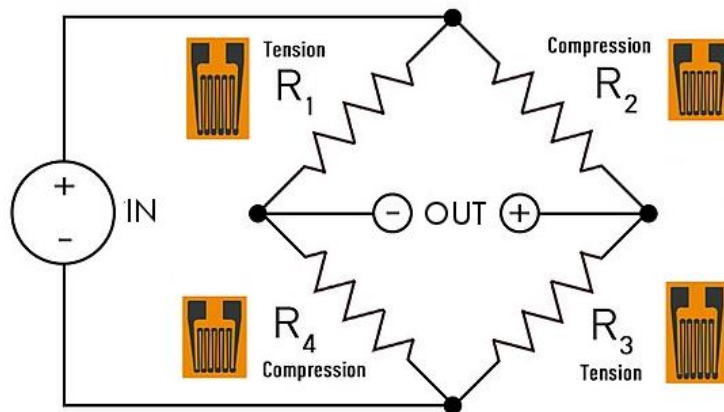

3. Type of cell loads

3.1. Single point load cells

3.1.1. Principle

Single point load cells are the most popular load cells in the world. They are used on most bench-top scales and in a wide range of applications. They use bending as a measuring principle.

“Single point” is not an appropriate definition for these load cells. “Platform” load cell would be far more applicable.

Unlike other load cells presented here, the load does not need to be applied through a single mounting point on the load cell. A single point load cell will accept a platform of specified dimensions (see “Dimensions of the platform” in the datasheet) that can be bolted directly to the load cell. The load can be applied anywhere on this platform, the measurement by the load cell will always be accurate.

- ▶ Its usual capacities range from 1 kg to 500 kg.



▲ Single load cell bench-top scales

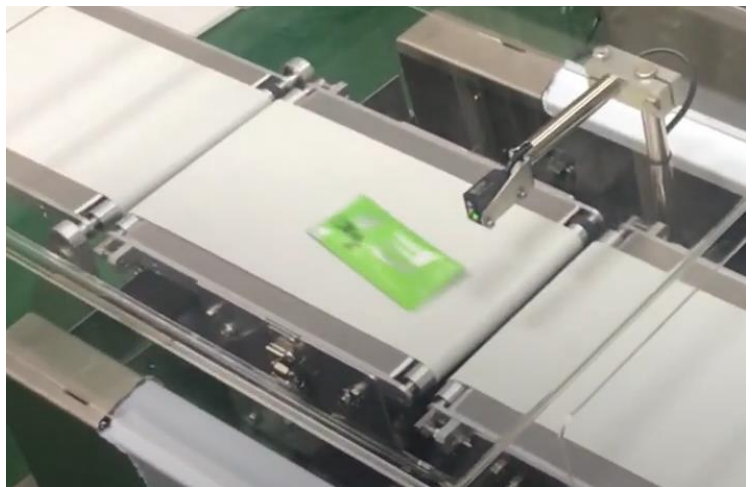

▲ Sorting labelling machine

3.1.2. AG and AVX single point load cell

SCAIME offers a comprehensive range of single point load cells, from 200 g to 600 kg. It offers low cost load cells for bench-top scale applications as well as fully welded stainless steel load cells suitable for the harshest environments.

Single load cell weighing platforms are generally constructed with the following types of load cells:

- The **AG** model, made of aluminium, with an IP65 protection provided by a coating, for use in standard industrial environments

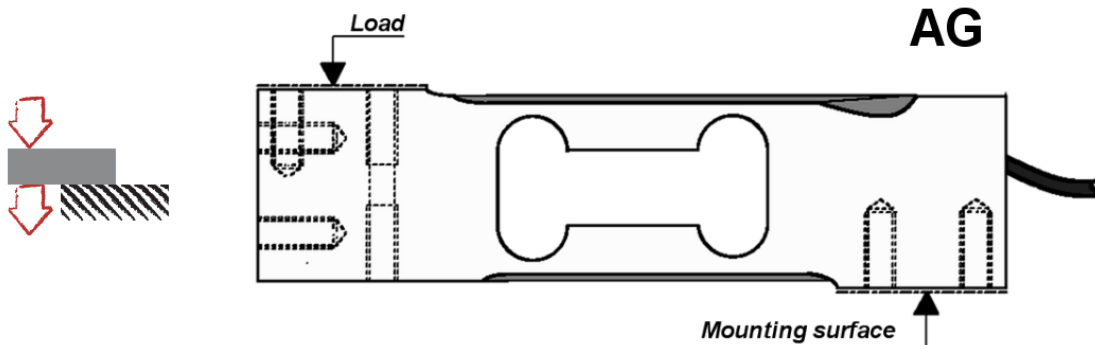

- The **AVX** model, made of stainless steel and hermetically welded for an IP68/IP69K protection, for use in wash down or corrosive environment.

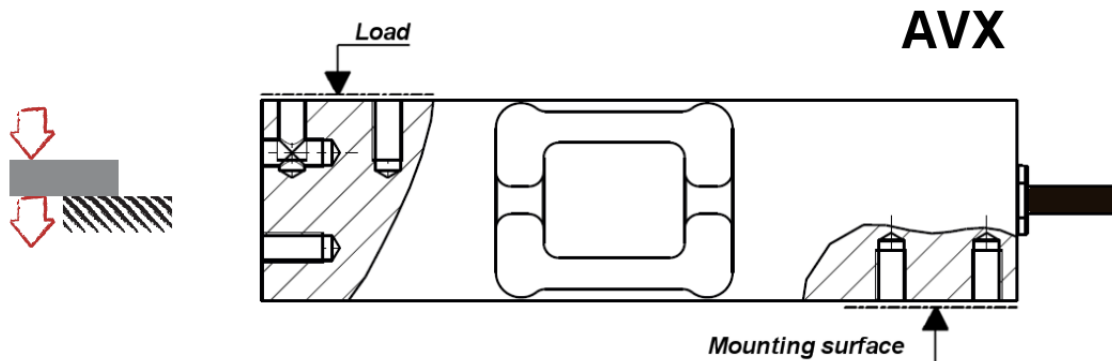

3.1.3. Load introduction

The following diagram shows a single point load cell typically used for scales.



- Install and adjust the appropriate overload stops to protect the load cell.
- Platform size must be less than the "Maximum platform size" (see datasheet).
- The load cell must be clamped in at the mounting holes, as a cantilever beam.
- The load cell must be fixed following the recommended tightening torques on a solid metallic base that won't flex under a load. The surface of this base must be machined and perfectly flat.

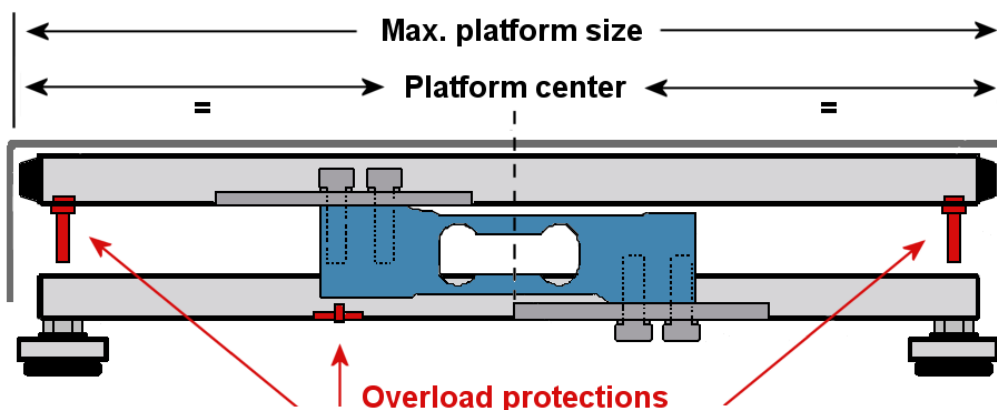

- If the body of the load cell does not incorporate the offset that allows some flexibility when the load is applied, place shims at the load cell mounting points (generally > 1 mm).

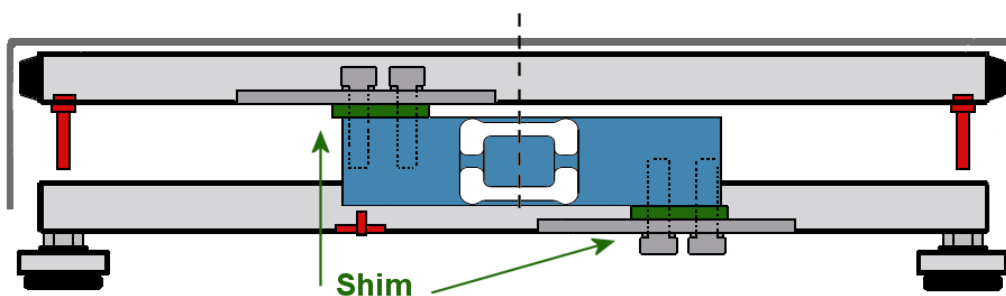

3.1.4. Offset adjustment of a single point load cell

Each single point load cell is individually adjusted at the factory to measure, without exceeding the permissible error, an off-centre load within the limits of the maximum platform size. This adjustment is carried out in accordance with OIML recommendation R76, with the application of a weight equal to a **third** the capacity of the platform, positioned at a **quarter** length of the surface.

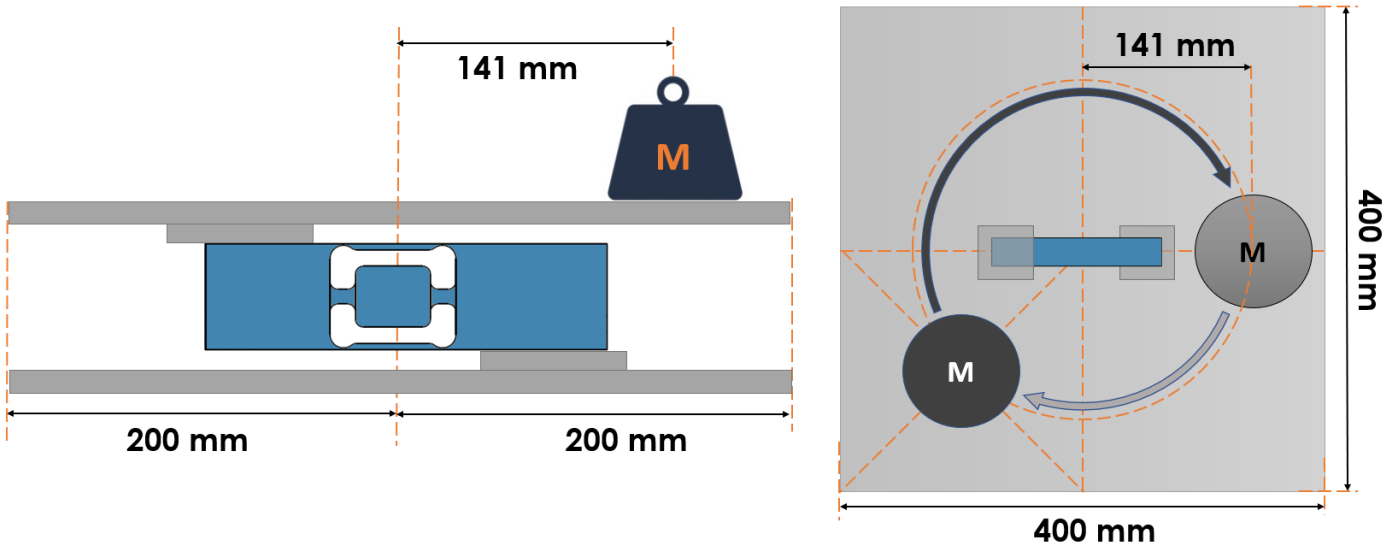

3.2. *Bending beam load cells*

3.2.1. Principle

Bending as a measuring principle offers excellent linearity. Bending beams generate high strain levels at relatively low forces with greater deformation compared to other measuring principles. This in turn means that although the bending beam load cell is subjected to greater static overload, mechanical stops are more feasible. The dynamic overload capabilities are excellent because of this typically high deformation.

Bending beam load cells can be used in platform scales, weighing systems in small hoppers, continuous belt weighing and weight feeders and other high precision applications.

- ▶ **Bending beam load cells are often used for capacities ranging from 5 kg to 500 kg.**



▲ Weighing in small hoppers

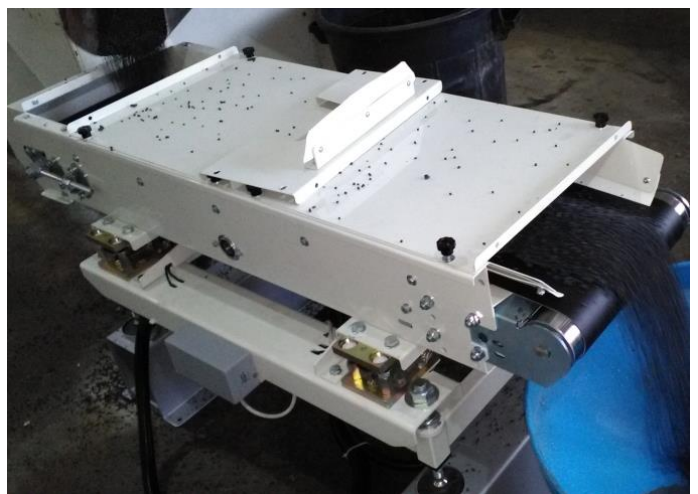

▲ Belt weighing

3.2.2. F60X bending beam load cell

The F60X bending beam load cell is made of stainless steel and hermetically sealed to IP68. It is particularly suitable for wash-down situations such as food processing plants.

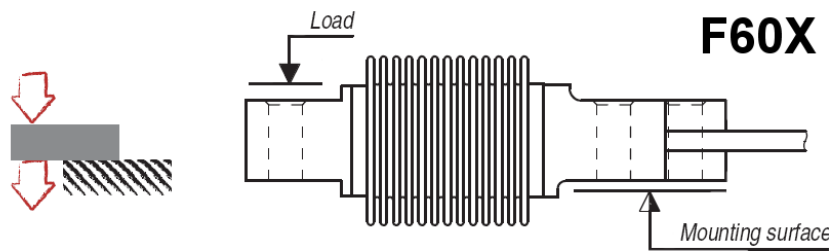

3.2.3. Load introduction

The load should be introduced vertically as much as possible. Torsion moments, off-centre loads and transverse forces cause measurement errors and are likely to damage the load cell. These adverse influences must be avoided, e.g. by using stay rods or guide rolls. These elements must not influence the load or force components in the direction of measurement (vertical).

The following points must be considered with attention:





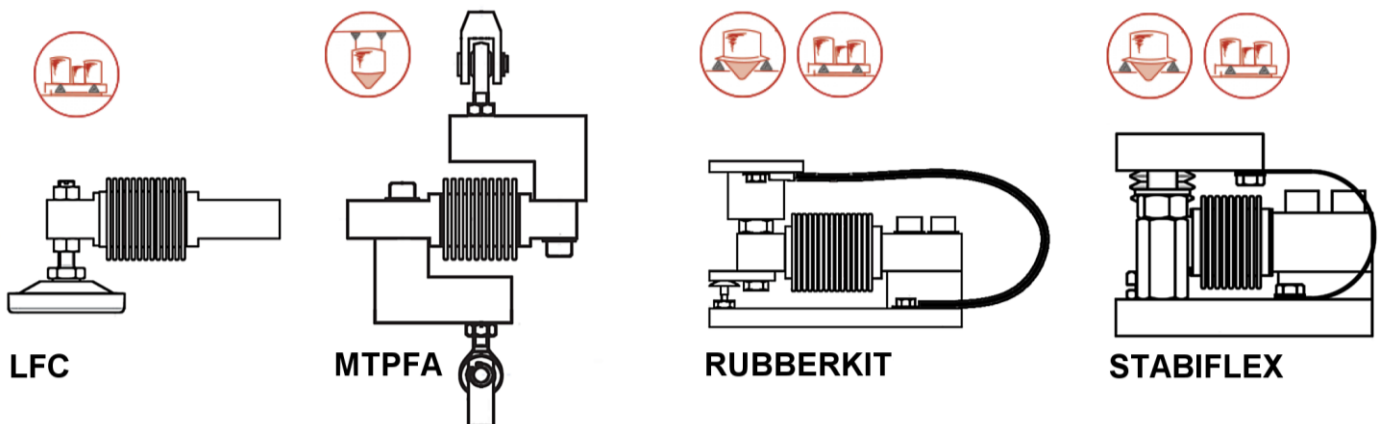

- The load cell and especially the thin-walled bellows must be handled with care.
- Do not overload the load cell, not even for a short time. When handling and mounting load cells with small rated capacities, permissible limit values will be quickly reached.
- The load cell seating must be horizontal, on a flat, hard and perfectly clean surface, as the load cell base.
- Never load in a direction opposite to the load direction specified (see datasheet).
- Load cells are to be clamped tightly to the mounting components. Refer to the datasheet for the recommended tightening torques.

SCAIME offers different mounting components for various mounting situations in order to minimise the adverse effects due to load introduction or environmental factors.



- **LFC, LFD:** Swivel foot designed for platform scales manufacturing.
- **MTPFA:** Roll and ball joint tension mounting kit, designed for weighing devices in suspended hoppers and mechanical weighbridge refurbishment.
- **RUBBERKIT:** Mounting kit including elastomer for misalignment compensation and vibration or shock absorption. Designed for weighing systems for small tanks or hoppers with agitators.
- **STABIFLEX:** Compression mounting kit including built-in side stops, lift-off prevention and high precision ball and cup de-coupling. The kit can be fitted with a stabilising tie rod to prevent movement within the structure.

Selection guide for mounting kits for bending beam load cells

| | LFC, LFD | MTPFA | RUBBERKIT | STABIFLEX | |
|-----------------------------------|---|---|--|---|--------|
| |  |  |  |  | |
| Main characteristics | | | | | |
| Construction | Nickel plated steel Stainless steel | Galvanised steel | Stainless steel | Galvanised steel Stainless steel | |
| Application | Swivel foot | Weighing in suspended hoppers | Weighing in platforms, conveyor belts, tanks and mixers | Weighing in platforms, conveyor belts, tanks and mixers | |
| Load cell capacity | 5 kg ... 500 kg | 5 kg ... 300 kg | 5 kg ... 300 kg | 5 kg ... 500 kg | |
| Functions | | | | | |
| Floor mounting | - | - | Bolted | Bolted | |
| Structure mounting | Bolted | Bolted | Bolted | Bolted | |
| Accuracy | ●●● | ●●● | ●● | ●●●● | |
| Height adjustment | ●●● | ●● | - | - | |
| Tilt fault | ●●● | ●●● | ●● | ●● | |
| Structure expansion | ● | ●●● | ●● | ●●●● | |
| Vibration damping | ● | - | ●●● | - | |
| Lateral security | - | ● | ●● | ●●●● | |
| Lateral support | - | - | ●●● | ● / ●●●● (stab) | |
| Lift-off prevention | - | - | ● | ●●●● | |
| Hold without the load cell | - | - | - | ●●●● | |
| | ●●●● Excellent | ●●● Good | ●● Average | ● Low | - None |

3.3. Shear beam load cells

3.3.1. Principle

Shear beam load cells are especially suited for all types of medium and high capacity weighing applications. This load cell is bolted to a fixed structure at one end and force is applied through a single point at the other end, causing the beam to bend and placing the strain gauge area under shear.

Shear as a measuring principle offers a good resistance against side loads and small sensitivity to the variation in the loading position.

Distribution des contraintes le long de la section AA du barreau.

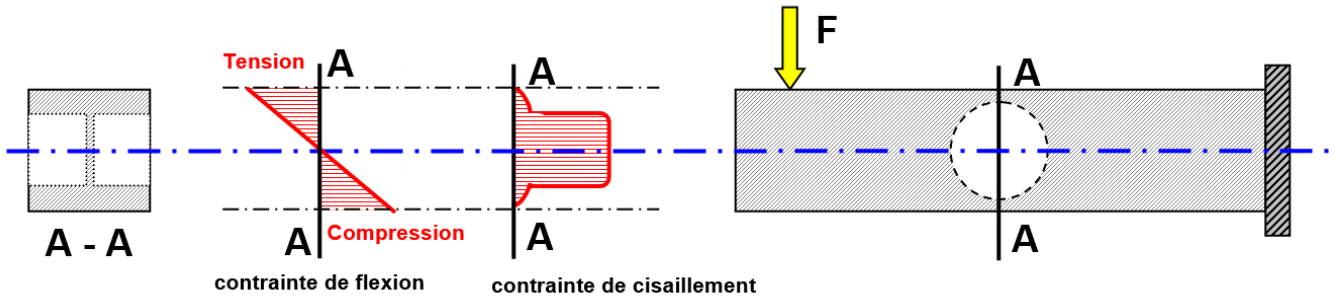

At the **AA** cross-section of the beam, a cavity is made on each side, leaving a small thickness in the centre. As in an "I-shaped" bar, a large part of the shear stress is taken by the core, while the bending moment is borne by the sides. In these conditions, along the neutral axis, where the bending stress is negligible, the stresses on the core of the load cell are only shear stresses.

► **On this neutral axis, the shear stress is independent of the point where the load is applied.**

The shear beam load cell is the most commonly used load cell for a large number of weighing applications in difficult environments. They are generally used with special swivel feet and mounted in the corners of large platform scales. They are also used for weighing vessels.

When compared to bending beam load cells, they provide:

- A measurement which independent from the point of application of the load,
- Better resistance to side forces,
- Better overload capacity, even though mechanical stops are more difficult to adjust because of their limited deflection at full scale.

► **Shear beam load cells are often used for capacities ranging from 300 kg to 5,000 kg.**

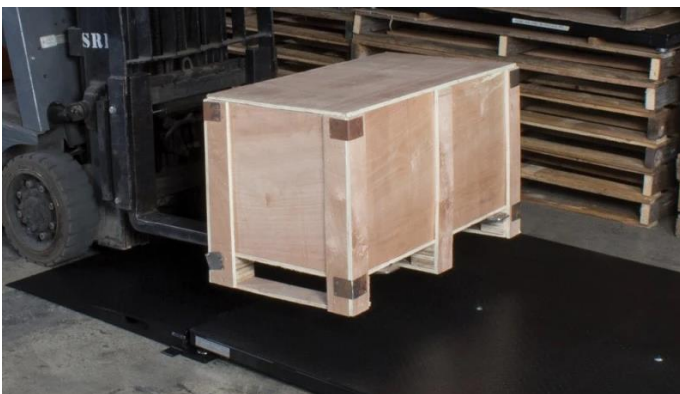

▲ Weighing platforms with multiple load cells

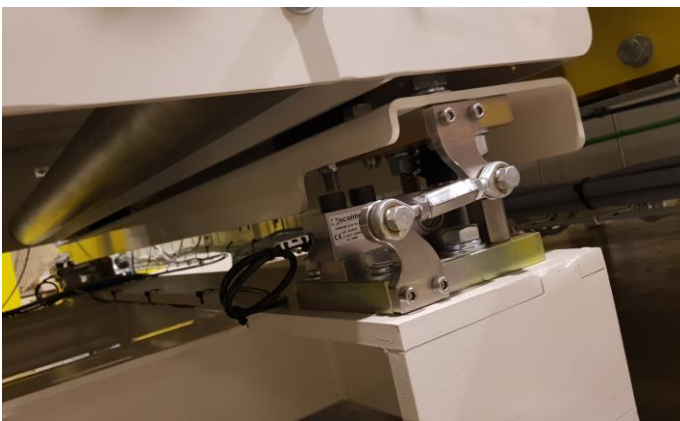

▲ Conveyor weighing



▲ Weighing of tanks or silos

3.3.2. SK30X shear beam load cell

The SK30X shear beam load cell is made of stainless steel and hermetically sealed to IP68. It is extremely suitable for wash-down situations and sanitary environments such as dairies and food processing plants.

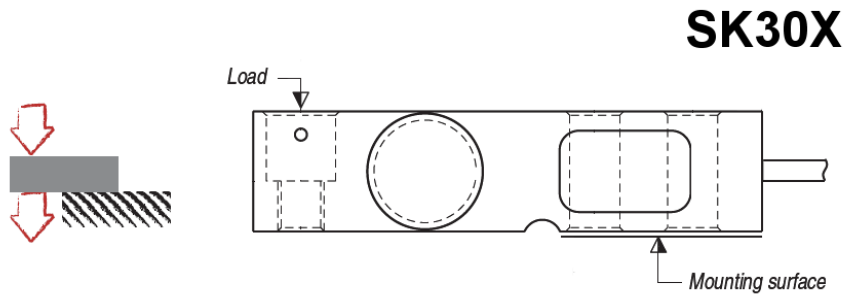

3.3.3. Load introduction

The load should be introduced vertically as much as possible. Torsion moments, off-centre loads and transverse forces cause measurement errors and are likely to damage the load cell. These adverse influences must be avoided, e.g. by using stay rods or guide rolls. These elements must not influence the load or force components in the direction of measurement.

SCAIME offers different mounting components for various mounting situations in order to minimise the adverse effects due to load introduction or environmental factors.

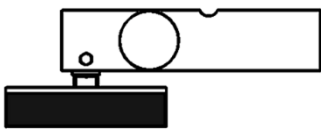
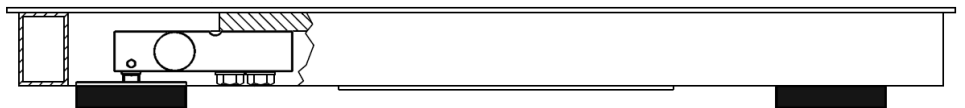

LFA

- **LFA:** Swivel foot designed for platform scales manufacturing.

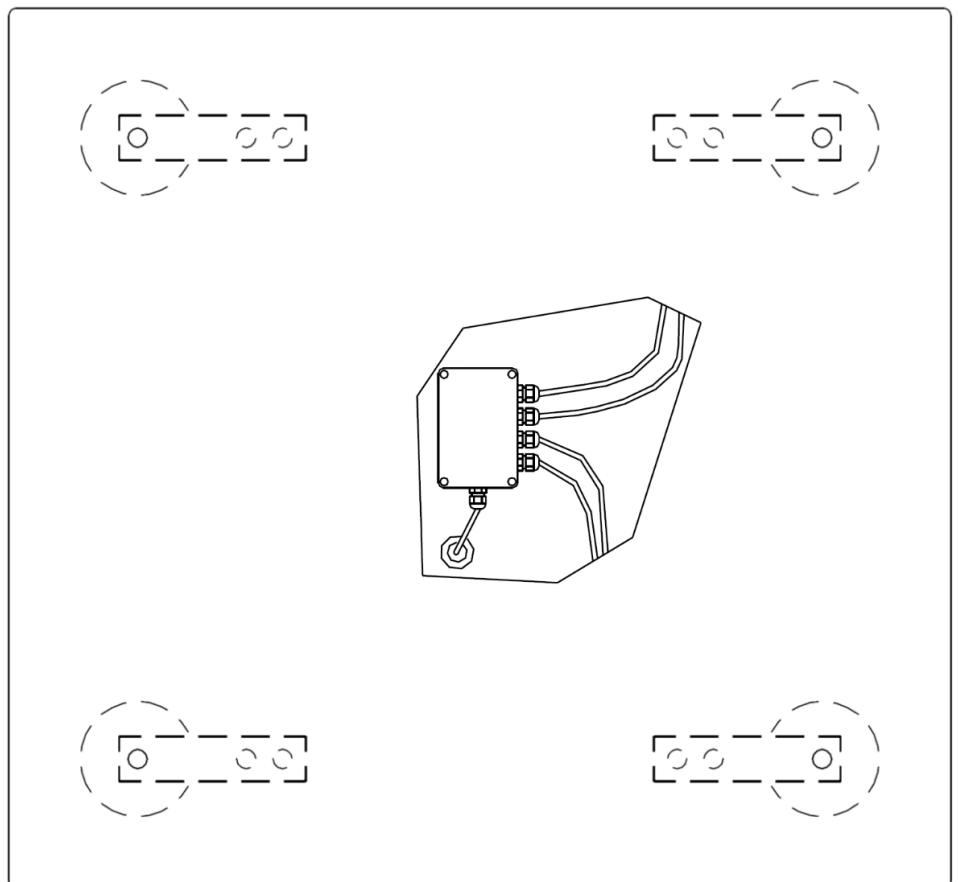

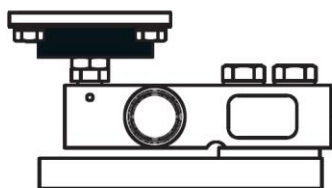

QUICKFIT

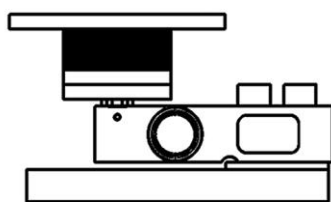

ISOFLEX

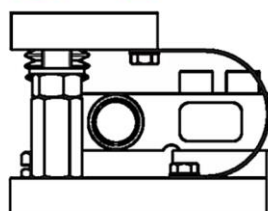

STABIFLEX

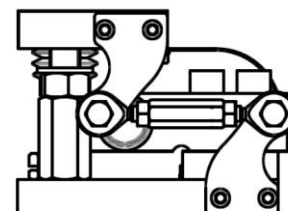

STABIFLEX-STAB

- **QUICKFIT:** Mounting kit with vibration-absorbing elastomer and swivel feet for accurate weighing.
- **ISOFLEX:** Mounting kit including elastomer for misalignment compensation and vibration or shock absorption. Designed for weighing systems for small tanks with agitators.
- **STABIFLEX:** Mounting kit including built-in side stops, lift-off prevention and high precision ball and cup de-coupling for accurate weighing. The kit can be fitted with a stabilising tie rod to prevent movement within the structure.

Selection guide for mounting kits for shear beam load cells

| | LFA | QUICKFIT | ISOFLEX | STABIFLEX |
|--|-----|----------|---------|-----------|
| | | | | |

| Main characteristics | | | | |
|-----------------------------------|-----------------|---|---|---|
| Construction | Stainless steel | Stainless steel | Galvanised steel | Galvanised steel Stainless steel |
| Application | Swivel foot | Weighing in platforms, conveyor belts, tanks and mixers | Weighing in platforms, conveyor belts, tanks and mixers | Weighing in platforms, conveyor belts, tanks and mixers |
| Load cell capacity | 300 kg ... 5 t | 300 kg ... 5 t | 300 kg ... 5 t | 300 kg ... 5 t |
| Functions | | | | |
| Floor mounting | - | Bolted | Bolted | Bolted |
| Structure mounting | Bolted | Bolted or welded | Bolted | Bolted |
| Accuracy | ●●● | ●●● | ●● | ●●●● |
| Height adjustment | ●●● | ●●● | - | - |
| Tilt fault | ●●● | ●●●● | ● | ●● |
| Structure expansion | ● | ●●● | ●● | ●●●● |
| Vibration damping | ● | ● | ●●● | - |
| Lateral security | - | ● | ● | ●●●● |
| Lateral support | - | ●● | ●●● | ● / ●●●● (stab) |
| Lift-off prevention | - | - | - | ●●●● |
| Hold without the load cell | - | - | - | ●●●● |

●●●● Excellent ●●● Good ●● Average ● Low - None

3.4. S-type load cells

3.4.1. Principle

S-type load cells are most commonly used in tension (but can be used in compression). This type of load cell uses bending or shear as a measuring principle. It must be installed so that the force applied passes vertically through the centre of the load cell.

S-type load cells are used for vessel weighing, tensile testers, torque restraints and other applications.

- ▶ **S-type load cells are commonly used in capacities from 25 kg to 5,000 kg.**

3.4.2. ZA30X S-type load cell

The ZA30X S-type load cell is made of stainless steel and hermetically sealed to IP68. It is extremely suitable for wash-down situations and sanitary environments such as food processing plants.

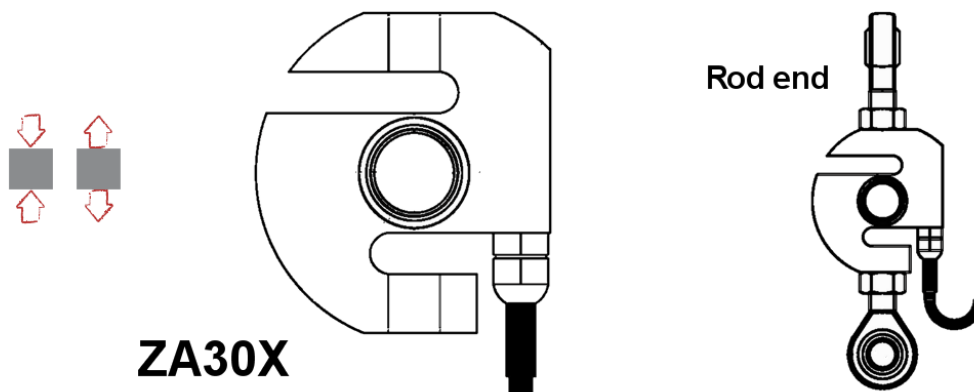

3.4.3. Load introduction

The threaded boreholes at the top and bottom are used for the load introduction. The load should be introduced as closely as possible in the direction of measurement. Torsion and bending moments cause measurement errors and are likely to damage the load cell. These adverse influences must be avoided by construction elements which will not influence the weight measurement.

SCAIME provides ball joints to minimise adverse effects due to load introduction:

- The ball joint nuts must be tightened at maximum load.
- Do not apply the tightening torque to the load cell.

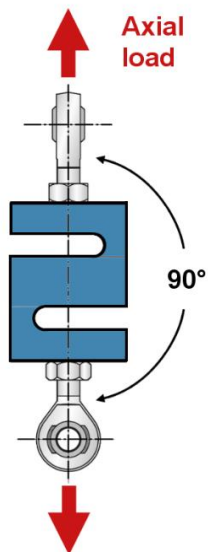

When using S-type load cells for vessel weighing:

- Position the load cells around the tank so that each one supports the same weight.
- To reduce swaying, ensure the upper and lower rod end are turned at a 90° angle from one another.
- Install a safety device next to each weighing module.
- Ensure the load cell is hanging vertically.

If the suspended tank is subjected to horizontal movement, install check rods to limit that movement.



- **The force must be applied axially to the load cell.**

3.5. Column compression load cells

3.5.1. Principle

Although conceptually simple, the column compression load cell has a number of specific characteristics which makes these load cell types difficult to design and produce. The column itself should be long enough, with respect to its cross section, to provide a uniform deformation field. Column load cells are inherently non-linear while deforming under load. This non-linearity is compensated with specific semiconductor gauges.

For this type of cell load, the amount of movement accumulated is less important than with beam load cells. Therefore, their overload capabilities are excellent. However, the relatively small deflection makes this load cell type more sensitive to shock loading.

Column load cells offer high accuracy, so they are often used in weighbridges and vessel weighing when high accuracy is required.

- ▶ **Column load cells are commonly used in capacities from 5 t to 200 t.**



▲ *Truck weighing*



▲ *Silo weighing*

3.5.2. **CB50X** compression column load cell

The CB50X is made of stainless steel and hermetically sealed to IP68. This makes it particularly suitable for harshest environments such as chemical and food processing plants.

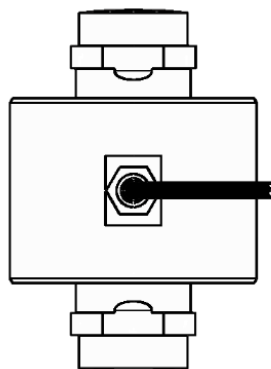

CB50X

3.5.3. **Load introduction**

SCAIME offers different mounting components in order to minimise the adverse effects due to load introduction or environmental factors.

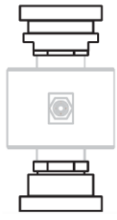

LPC

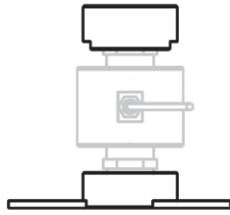

LPS

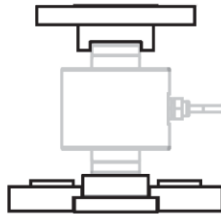

LPM

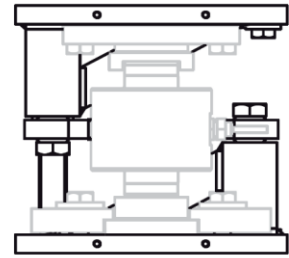

STABICAN

- **LPC, LPS, LPM:** Weighbridge mounting kit with anti-rotation device.
- **STABICAN:** Compression mounting kit including built-in lateral stabilisation rods and lift-off prevention. Designed for silo weighing.

Selection guide for mounting kits for compression column load cells

| | LPC | LPS | LPM | STABICAN |
|-----------------------------------|---------------------|---------------------|--|-------------------------------------|
| | | | | |
| Main characteristics | | | | |
| Construction | Nickel plated steel | Nickel plated steel | Nickel plated steel Stainless steel | Galvanised steel Stainless steel |
| Application | Weighbridge | Weighbridge | Weighbridge Silo weighing | Silo weighing |
| Load cell capacity | 5 t ... 60 t | 5 t ... 60 t | 5 t ... 60 t | 5 t ... 200 t |
| Functions | | | | |
| Floor mounting | - | Eccentric | Brackets | Bolted |
| Structure mounting | - | Bolted | Bolted | Bolted |
| Accuracy | ●●●● | ●●●● | ●●●● | ●●●● |
| Height adjustment | - | - | - | - |
| Tilt fault | ●●● | ●●● | ●●● | ●● |
| Structure expansion | ●●● | ●●● | ●●● | ●●● |
| Vibration damping | - | - | - | - |
| Lateral security | - | - | - | ●●● |
| Lateral support | - | - | - | ●●● |
| Lift-off prevention | ● | ● | ● | ●●●● |
| Hold without the load cell | - | - | - | - |
| Anti-rotation | ●●● | ●●● | ●●● | ●●● |
| | ●●●● Excellent | ●●● Good | ●● Average | ● Low |
| | | | | - None |

3.5.4. Installation in weighbridge applications

The CB50X is a pendulum load cell designed to automatically restore the mounting construction to a stable initial position in the event of a small lateral displacement of the load introduction. This assembly, ideally suited for weighbridge applications allows free motion in any direction in the horizontal plane.

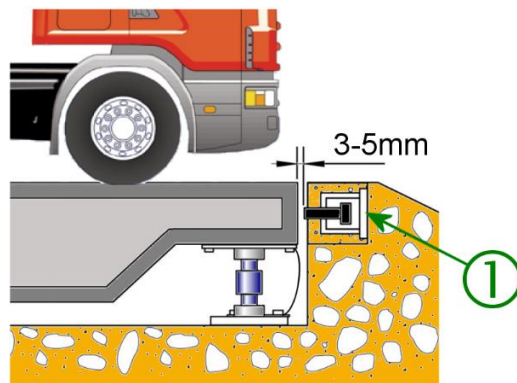
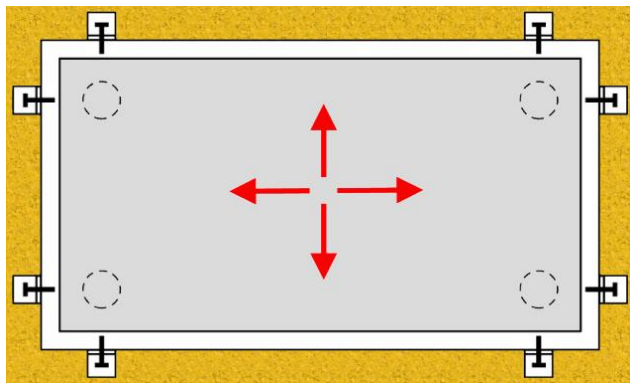

- Install and adjust appropriate stops①.
- The base and load plates should be seated on a steel plates. These mounting surfaces must have a flatness $< 2/1000$ and an horizontality $< 4/1000$.



- The load cells must be placed in an upright position and on the same horizontal level.
- The maximum permissible lateral displacement or slope must not be exceeded.

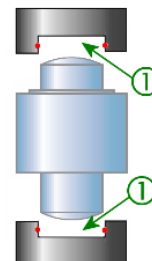
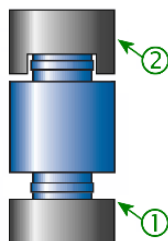
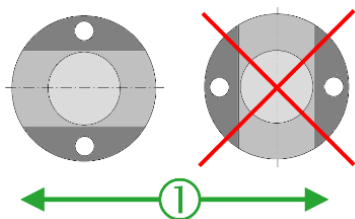

- The plates should be aligned in such way that the flat part of the rotation-stop device is parallel to the main traffic direction on the weighbridge①.
- To protect the bearing surfaces from wear, tear, and dirt, clean and grease the elements①.
- To avoid clogging the rotation-stop device, place the rotation-stop ② in a high position.

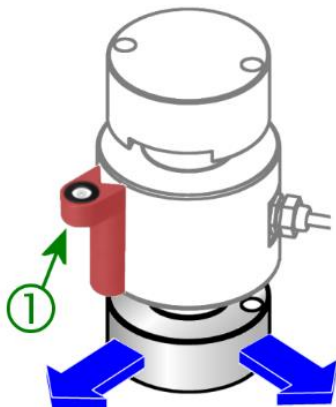

- Use an appropriate spirit level to check that the load cell is perpendicular to the mounting position.
- Align the load cell vertically with a spirit level①.

3.6. Low profile compression load cells

3.6.1. Principle

The deflection of the load cell by the load is measured by the flexible gauges positioned inside a sealed cavity in the load cell. The load cell converts the deflection into an electrical signal which is directly proportional to the load increase or decrease. Unwanted side loads will not affect the accuracy.

The low profile compression load cell is less precise than the column compression load cell, but its very compact profile makes it perfect for weighing vessels and silos. Its design also keeps the vessel's centre of gravity low, improving the vessel's stability. Installation is simpler than the column compression load cell.

► **Low profile compression load cells are used in capacities from 5t to 1000t.**



◀
Silo weighing

3.6.2. R10X low profile compression load cells

SCAIME provides the stainless steel R10X which is hermetically sealed (IP 68). This load cell is particularly suitable for measuring bulk material in sanitary and clean-in-place environments.

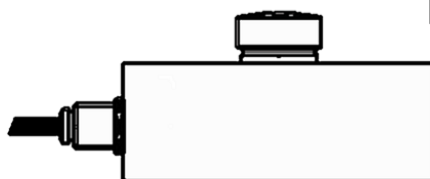

R10X

3.6.3. Load introduction

SCAIME provides mounting kits in order to minimise the adverse effects due to load introduction or environmental factors.

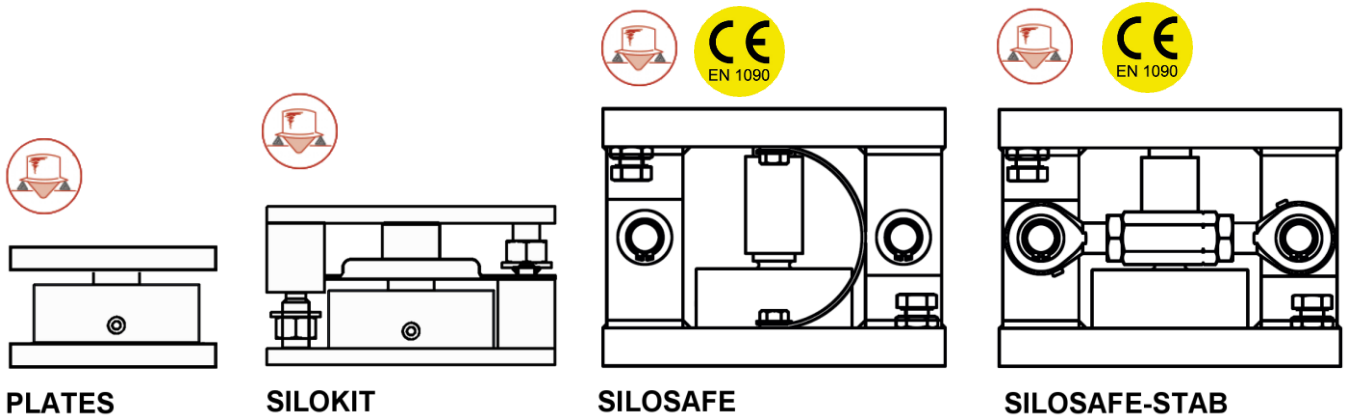

- **Plates:** Support plate and load button for integration into a user assembly.
- **SILOKIT:** Cost-effective load cell including built-in stabilisation plate and lift-off prevention. Designed for silo weighing.
- **SILOSAFE:** High performance mounting kit, **EN1090** certified for silo weighing. Incorporates lateral stops, lift-off prevention device and pendulum mounting for high precision weighing. The kit can be fitted with stabilising tie rods to prevent movement within the structure.

Selection guide for mounting kits for low profile compression load cells

| | PLATES | SILOKIT | SILOSAFE | SILOSAFE-STAB |
|-----------------------------------|---------------------|-----------------|-------------------------------------|---|
| | | | | |
| Main characteristics | | | | |
| Construction | Nickel plated steel | Stainless steel | Galvanised steel Stainless steel | Galvanised steel Stainless steel |
| Application | Silo weighing | Silo weighing | Silo weighing | Silo weighing Mobile weighing structures |
| Load cell capacity | 250 kg ... 100 t | 250 kg ... 30 t | 250 kg ... 300 t | 250 kg ... 50 t |
| Functions | | | | |
| Floor mounting | - | Eccentric | Brackets | Bolted |
| Structure mounting | - | Bolted | Bolted | Bolted |
| Accuracy | ●●● | ●● | ●●●● | ●●●● |
| Height adjustment | - | - | - | - |
| Tilt fault | ●●● | ●● | ●●● | ●●● |
| Structure expansion | - | ● | ●●●● | ●●●● |
| Vibration damping | - | - | - | - |
| Lateral security | - | ●● | ●●●● | ●●●● |
| Lateral support | - | ●●● | ● | ●●●● |
| Lift-off prevention | - | ●● | ●●●● | ●●●● |
| Hold without the load cell | - | ●● | ●●●● | ●●●● |
| EN1090 | - | - | ●●●● | ●●●● |
| | ●●●● Excellent | ●●● Good | ●● Average | ● Low - None |

3.6.4. Compliance with standard EN1090

In Europe, the regulation on construction products (No. 305/2011) indicates that metallic structural elements in buildings, placed on the market, must comply with standard **EN1090** and receive a **CE marking**.

Thus, for silo weighing, the mounting kits for load cells can be considered by the client as load-bearing elements and must comply with standard EN1090.

- The client defines an execution class (EXC) to which the manufacturer must respond, depending on the type of building and the human and material risks, in the event of failure.
- Depending on the execution class, standard EN1090 describes the design, manufacturing and implementation requirements applicable to the product.

To meet this requirement, SCAIME has had its quality system certified according to standard EN1090 in execution class **EXC2**. This class implies that the entire process, from product design to delivery, is taken into account within a qualified and documented system.



An EN1090 certified mounting kit in EXC2 class guarantees:

- **The existence of a quality documentation system**
- **The existence of a procedure for dealing with non-compliances**
- **Bearing capacity dimensioned according to standard EN1993-1**
- **Traceability of materials used**
- **Product meets specifications**
- **Manufacture by qualified welders and operators**



3.7. Load pins

3.7.1. Principle

A load measuring pin senses the force applied across it, via strain gauges installed within a small bore through the centre of the pin. Two grooves are machined into the outer circumference of the pin to define the shear planes, which are located between the forces being measured.

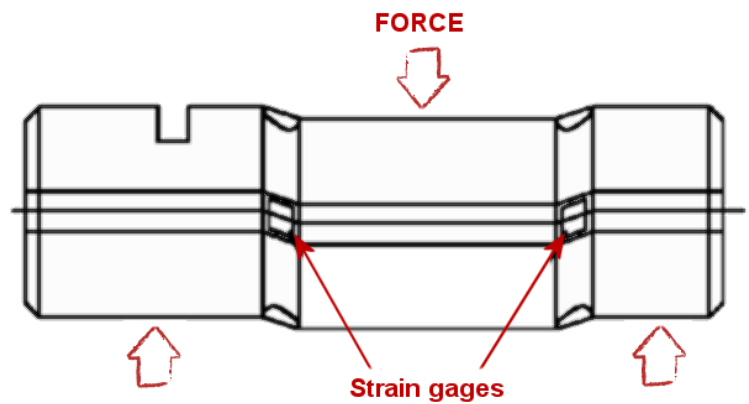
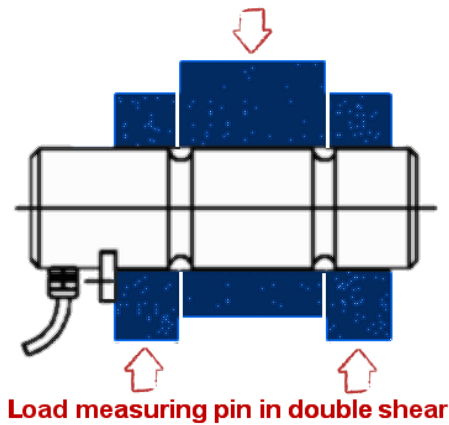

Load measuring pins are designed for many diverse applications as direct replacements for clevis or pivot pins. Their main advantage is that they do not normally require any change to the structure being monitored.

- ▶ Its usual capacities range from 20 kg to 100 t.



▲ Load control on a pulley



▲ Load control on a screed



▲ Weighing tanks mounted on axes

3.7.2. M16 load pin

The most common type available is the M16, ideally suited for load measurement and overload protection on cranes, hoists, fork lift trucks and winches.

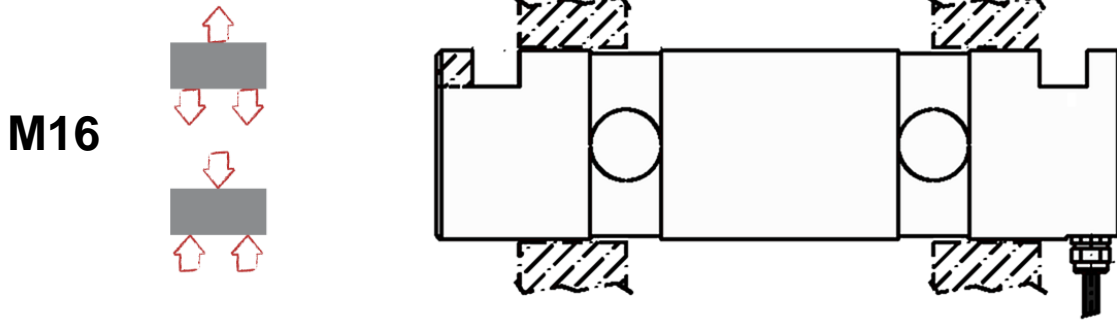

3.7.3. Typical installations

If the load to be measured is applied to the existing axis in a perfectly defined direction, then an M16 load pin can be installed to measure that load. The diagrams below show typical locations for load pins.

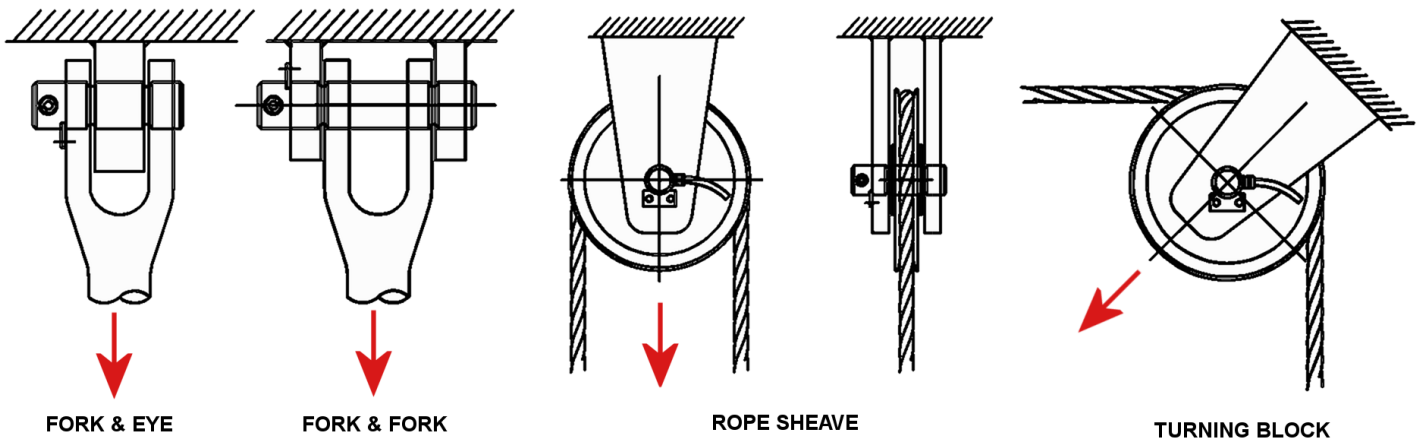

3.7.4. Load pin locking system

A load pin needs to be locked into position in order to set its direction. For an accurate measurement, the load pins must be set to avoid any axial and rotational movement.

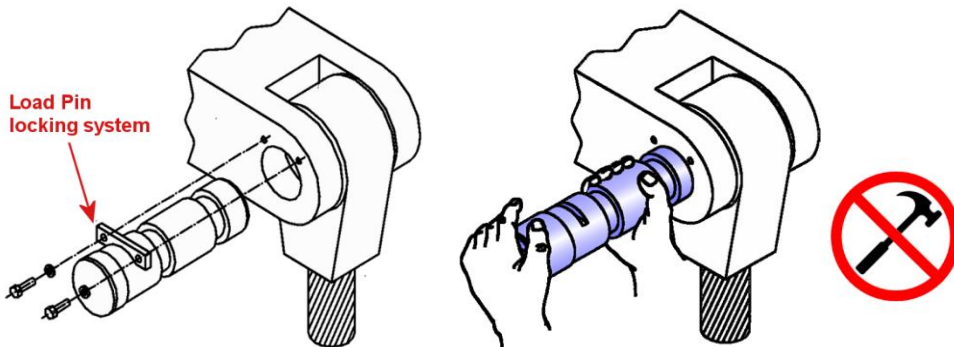

- **Manually slide the load pin into place. Never use a hammer or another tool to insert it.**

3.7.5. Calculating the measuring force

A standard load pin is designed to measure the force in one direction only. Be careful with the load pin mounting position to avoid measurement errors.

Resultant force measured by the load pin

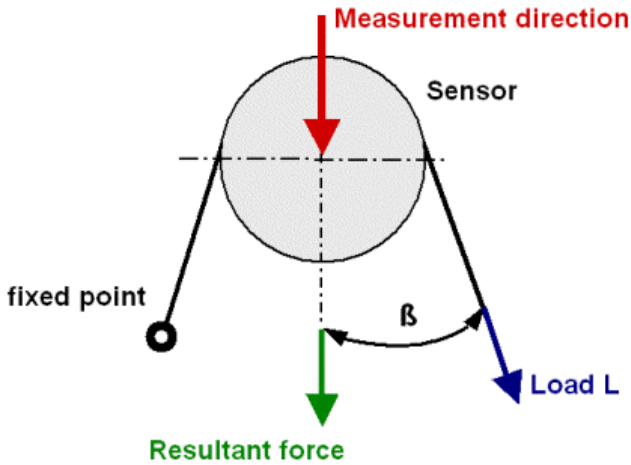

Beware of the resultant force measured by the load pins, which can be different from the load applied to the wire. The resultant force can be multiplied or reduced depending on the assembly:

$$\text{Resultant force (\%)} = 2 \times L \times \cos(\beta)$$

Error due to a change in load direction

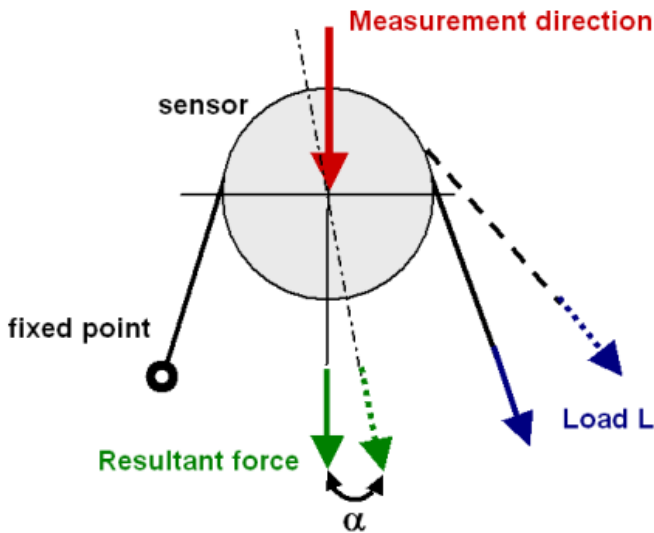

The direction of the load pin measurement should be in the same direction as the resultant force, if not, a measurement error (% of the applied load) can be calculated as follows:

$$\text{Error (\%)} = 100 \times [\cos(\alpha) - 1]$$

3.7.6. Mounting considerations

The load pin must be free to bend in its support. To do so, the following must be checked:

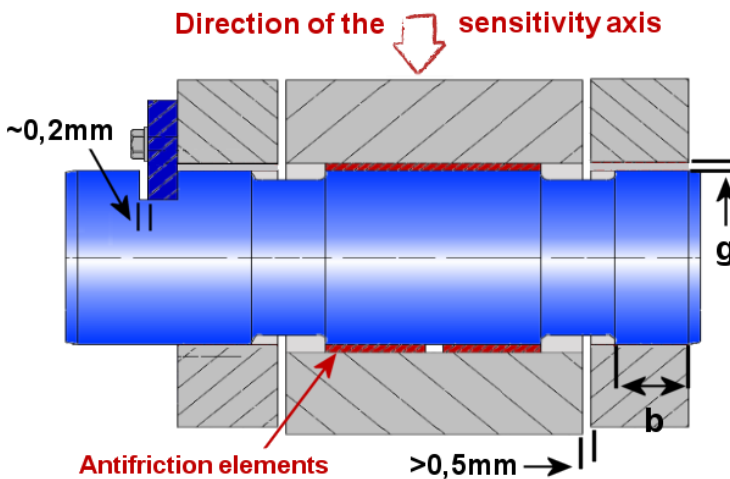

- $g \geq 0.01 \times b$ (generally $g \geq 0.2 \text{ mm}$)
- Leave a gap (~0.2 mm) between the locking system and the load pin mortise. Thus, no strain can be transmitted through the locking system.
- For better accuracy, the load pin should bear no radial effort or torque.
- To avoid any torque effects, the load must be free to rotate around the pin (use antifriction elements or bearings).

4. Load cell specifications

The following definitions will help you understand load cell datasheets.

4.1. Legal metrology specifications

Legal Metrology is the entirety of the legislative, administrative and technical procedures established by public authorities in order to ensure, in a regulatory manner, the appropriate quality of measurements related to official controls, trade, health, safety and the environment.

Several organisations set standards for the weighing industry and provide load cells regulations that will guarantee the scales accuracy.

In Europe, a test certificate for the load cell is given by the EU (European Union) notified body, according to recommendations set by the **OIML** (Organisation Internationale de Métrologie Légale - International Organisation of Legal Metrology).



The **OIML** is an intergovernmental organisation. It was established to promote the global harmonisation of legal metrology procedures. The OIML provides its members with metrological guidelines for the preparation of requirements concerning the manufacture and use of measuring instruments.

A manufacturer can obtain an OIML Certificate indicating that an instrument complies with the requirements of the relevant OIML International Recommendations. For weighing, the guidelines are as follows:

- **OIML R60:** List of requirements relating to load cells.
- **OIML R76:** Guidelines relating to non automatic weighing instruments (NAWI).
- **OIML R51:** Guidelines relating to automatic weighing instruments (NAWI), such as a sorting-labelling machine
- **OIML R61:** Guidelines relating to automatic weighing instruments (NAWI), such as a filling-weighing machine

4.1.1. Accuracy class

For a weighing instrument, two metrological characteristics are essential:

- **The verification scale:** this is the graduation on the instrument, also called "**interval**"
- **The weighing capacity** is the maximum weight that can be measured on an instrument

Regulatory texts do not set minimum values for these characteristics according to a given use, except when checking pre-packaged products for which a minimum level is required.

Metrological characteristics will therefore be defined in relation to the maximum permissible error for the application and the product to be weighed.

Non-automatic weighing instruments are tested and certified according to OIML R76 and classified according to their performance:

| Accuracy class of an instrument | Verification scale interval (e) | Number of verification scale intervals (n = Max/e) | |
|---------------------------------|---|--|---------|
| | | Min | Max |
| I - Special | $0.001g \leq e$ | 50 000 | - |
| II - High | $0.001g \leq e \leq 0.5g$ / $0.1g \leq e$ | 100/5 000 | 100 000 |
| III - Medium | $0.1g \leq e \leq 2g$ / $5g \leq e$ | 100/500 | 10 000 |
| IIII - Ordinary | $5g \leq e$ | 100 | 1 000 |

- **For commercial weighing applications or for checking manufacturing processes, class III, from 500 to 10 000 intervals, is the most commonly used.**

Load cells are considered a part of a weighing instrument, they are tested and certified according to the **OIML R60** recommendation and are classified according to their performance:

| Load cell accuracy class | Maximum number of intervals (n_{max}) |
|--------------------------|---|
| A - Special | > 50 000 |
| B - High | 100 000 |
| C - Medium | 10 000 |
| D - Ordinary | 1000 |

A load cell is classified by a letter (from A to D) and by its **maximum number of intervals (n_{max})**, expressed in units of 1000. For example, C3 represents class C with 3000 OIML intervals.

- ▶ **Load cells with strain gauges easily achieve an accuracy class of C or D. They therefore allow the construction of class III or IIII weighing instruments suitable for industrial and commercial weighing applications.**
- ▶ **These load cells are generally cost-effective, accurate, reliable with a long service life. In addition, they require little space for mounting and are therefore easy to install.**

4.1.2. Maximum permissible error - mpe

The graph below shows the maximum permissible error (mpe) vs. the number of intervals:

- For Class III measuring instruments (OIML R76).
- For a class C load cell with a $p_{LC} = 0.7$ (OIML R60).

The p_{LC} (0.7 by default) represents the error attributed to a load cell in a full weighing instrument.

OIML Acceptance tolerance table

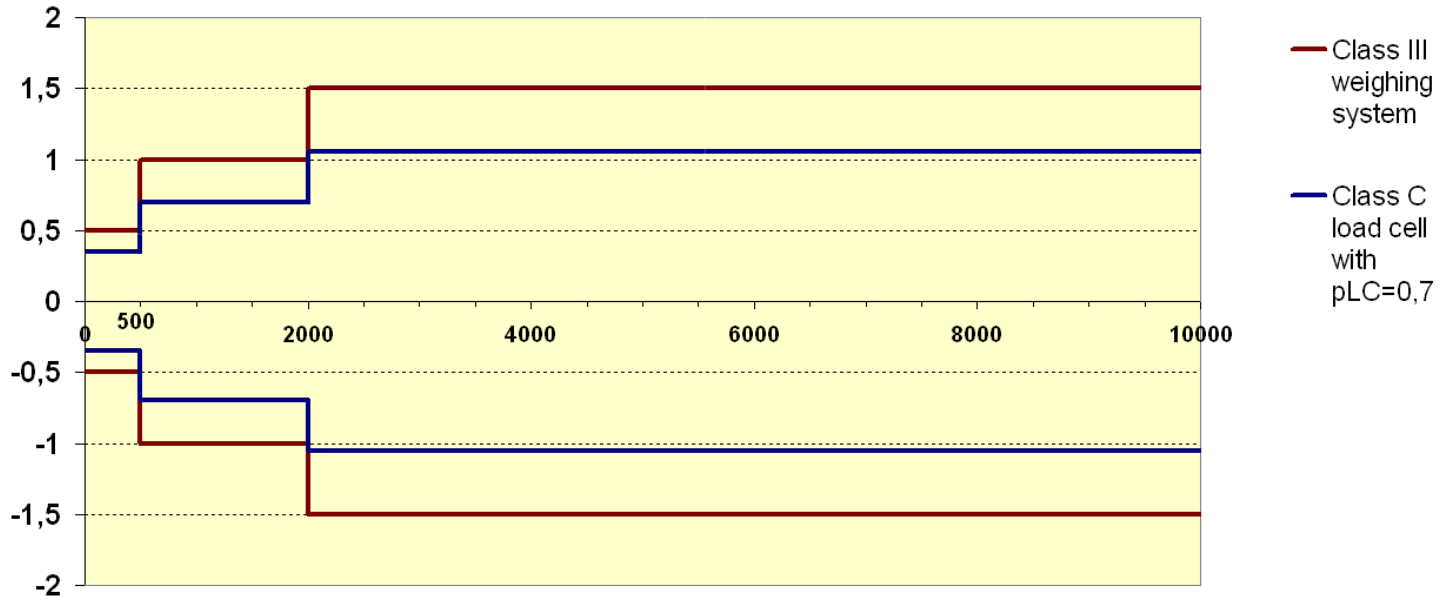

4.1.3. Minimum verification interval - V_{min}

For a load cell certified in legal metrology, this is the smallest mass value for which the measuring range can be divided without exceeding the maximum permissible error.

4.1.4. Maximum number of intervals - n_{max}

For a load cell certified in legal metrology, this is the maximum number of verification intervals for which the measuring range can be divided without exceeding the maximum permissible error.

4.1.5. Creep, reset to zero

- **Creep**

This is the temporal variation of the output signal of the load cell when subjected to a constant load. In legal metrology, the change in signal measured 30 minutes after the removing the load (>90% E_{max}) must not exceed 0.7 times the mpe for the applied load.

- **Minimum dead load output return (DR)**

In legal metrology, this is the difference in load cell output at minimum dead load, measured before and after a 30 minutes specific load application (>90% of the load cell capacity).

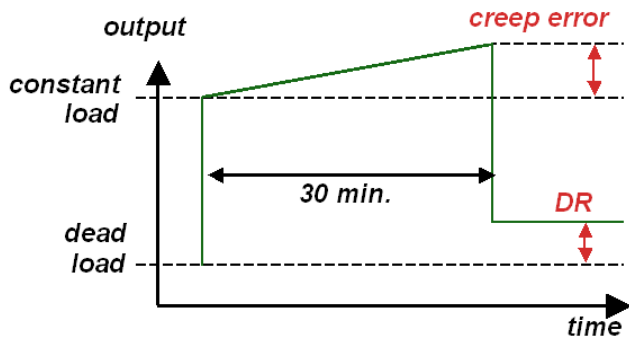

- For a load cell, returning to the minimum dead load will characterise its capacity to return to its initial value after applying a load.

4.2. Capacity specifications

- **Minimum dead load (E_{min})**

The smallest value of a quantity (mass) which may be applied to a load cell without exceeding the "mpe".

- **Maximum (E_{max}) and rated capacity**

The largest value of a quantity (mass) which may be applied to a load cell without exceeding the "mpe".

The rated capacity is the load that can be applied to achieve an output voltage equal to rated sensitivity. This load is usually equal to E_{max} .

The measuring range of the load cell is the legal operational range of the load cell, defined by E_{min} and E_{max} .

- **Safe load limit (E_{lim})**

The maximum load that can be applied without producing a permanent shift in the performance characteristics.

- **Ultimate overload**

This is the maximum load that can be applied without physically destroying the load cell.

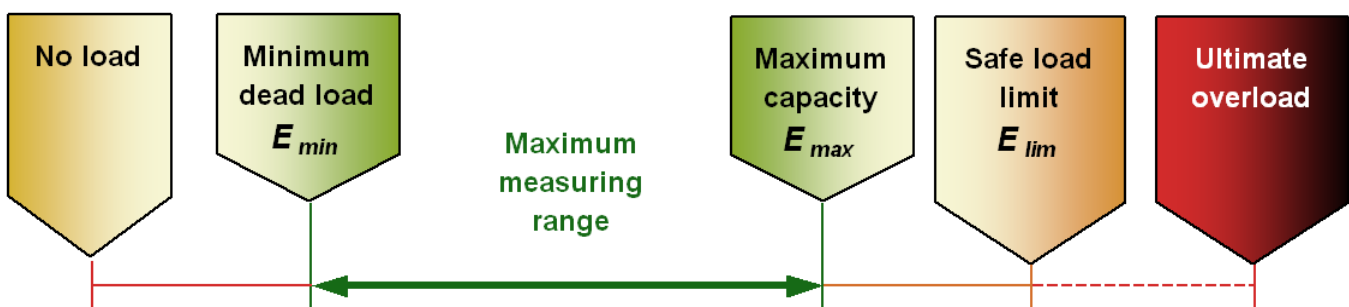

4.3. Metrological specifications

4.3.1. Combined error

In absence of any influence factors, the relationship between the load cell output signal, and the applied load will be a continuous curve exhibiting some non-linearity and hysteresis. The maximum output deviation between the calibration curve and the ideal curve is the combined error.

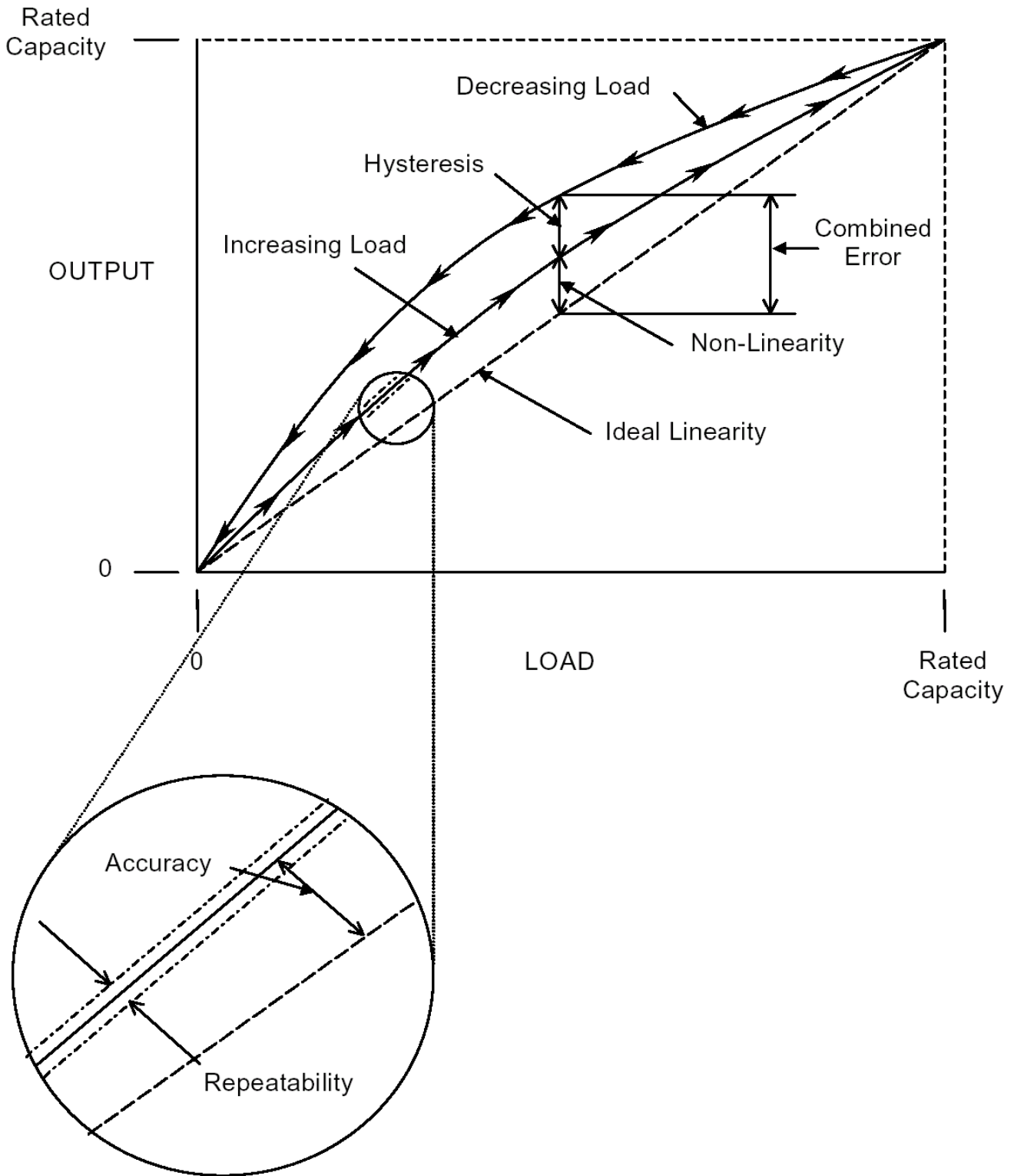

- **Non-linearity:** The deviation of the increasing load cell calibration curve from a perfect curve which passes through zero and through the load cell output voltage at the rated capacity.
- **Hysteresis:** The difference between load cell output values for the same applied load, one reading obtained by increasing the load from minimum load and the other by decreasing the load from nominal capacity.

4.3.2. Rated sensitivity

The value obtained by subtracting the unloaded output signal from the output obtained at rated capacity. Sensitivity is expressed by the value of the output voltage by unit of excitation voltage.

4.3.3. Temperature effect

There are two distinct temperature effect:

- **Temperature effect on zero:** This is the change in minimum dead load output signal due to a change in ambient temperature. In legal metrology, this change in signal must be $\leq P_{LC} \times V_{min}$ for a temperature variation of 5°C within the compensated temperature range.
- **Temperature effect on sensitivity:** This is change in sensitivity due to a change in ambient temperature. In legal metrology, it is important to stay within the **mpe** regardless of temperature variations, included in the compensated temperature range.

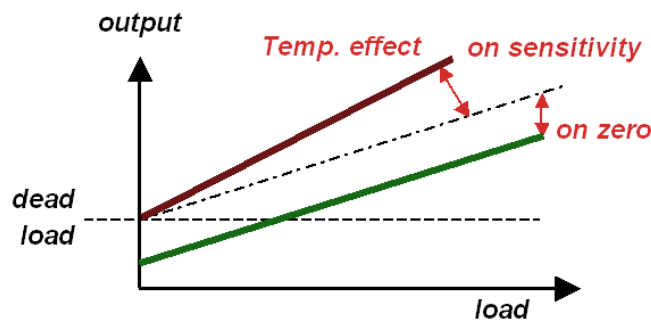

- **Compensated temperature range:** Without taking into account the temperature effects on Zero, the temperature range in which the output signal is compensated so as not to be affected by an error greater than the **mpe**.



- A common mistake is to think that the load cell signal remains in the mpe over the entire compensated temperature range, without a zero reset.
- The temperature variation of Zero is well compensated over the entire compensated temperature range, but only remains in the mpe ($V_{min} \times P_{LC}$) for a variation of 5°C within the full range.

- **Service temperature range:** The temperature range in which the load cell can be operated without permanent changes to its properties.

4.4. Electrical specifications

4.4.1. Electrical resistance

- **Input resistance:** Resistance measured across the input terminals with the output terminals opened under no-load conditions.
- **Output resistance:** Resistance measured across the output terminals with the input terminals opened under no-load conditions.
- **Insulation resistance:** Direct resistance measured between the load cell circuit and its casing, with a voltage of 50 VDC.

4.4.2. Nominal range of excitation voltage

The range of excitation voltage, DC or AC, is the range for which the measurement should not be affected by an error exceeding the load cell specifications.

4.5. Environmental protection level

No standard has been developed to cover load cells suitability for environmental conditions. In the absence of such standards, some load cells characteristics should be reviewed to determine the load cells suitability for specific conditions.

4.5.1. IP protection class

The IP standard (EN60529) describes the degree of protection provided by the casings of electrical equipment against the ingress of solid foreign objects and water ingress.

Although the IP standard is an acceptable starting point, it has some shortcomings:

- The IP system cannot clearly differentiate load cells of different constructions.
- The IP system does not take into account internal condensation or moisture within the casing.

4.5.2. Load cell sealing method

- **Potted:** Refers to load cells which have been environmentally sealed by a protective coating or by filling the strain gauge cavity with a material that protects the gauges from environmental hazards such as moisture. These load cells are usually used for indoor applications.
- **Enclosed:** Refers to load cells which have a strain gauge cavity filled with a potting compound. The cavity is also mechanically protected with side plates. These cells are protected from normal environmental factors in indoor or outdoor applications.
- **Hermetically sealed:** Refers to load cells which have a metallic protective cover welded to protect the strain gauge cavity. These load cells provide the best protection in harsh chemical or wash down environments.



- **A stainless steel load cell is not always hermetically sealed.**
- **While enclosed stainless steel load cells may be suitable for dry, chemical or corrosive environments, hermetically sealed stainless steel models are the appropriate choice for high moisture or wash down applications.**

4.5.3. SCAIME environmental classification chart

| Load cell sealing method | IP protection class |
|--------------------------|--|
| Potted | IP64/IP65 |
| Enclosed | IP67 |
| Hermetically sealed | IP68/IP69K (depending on test results) |

5. Designing a weighing system

Load cells may be used to weigh tanks, hoppers or vessels in various configurations. The installation of load cells requires compliance with several basic rules as well as a careful design in order for the system to be accurate and have a long service life.

5.1. *Compression versus tension*

Load cells measure forces in one of two directions: tension or compression. The use of a tension or compression system depends upon the mechanical structure around the vessel and the ease of creating the system.

5.1.1. Compressive mode

In the compressive mode, the conveyor, the vessel, the hopper or the silo is supported by load cells. If a vessel is to be placed on a concrete slab, compression will be the most suitable method, because a tensile system would require the addition of an expensive suspension.

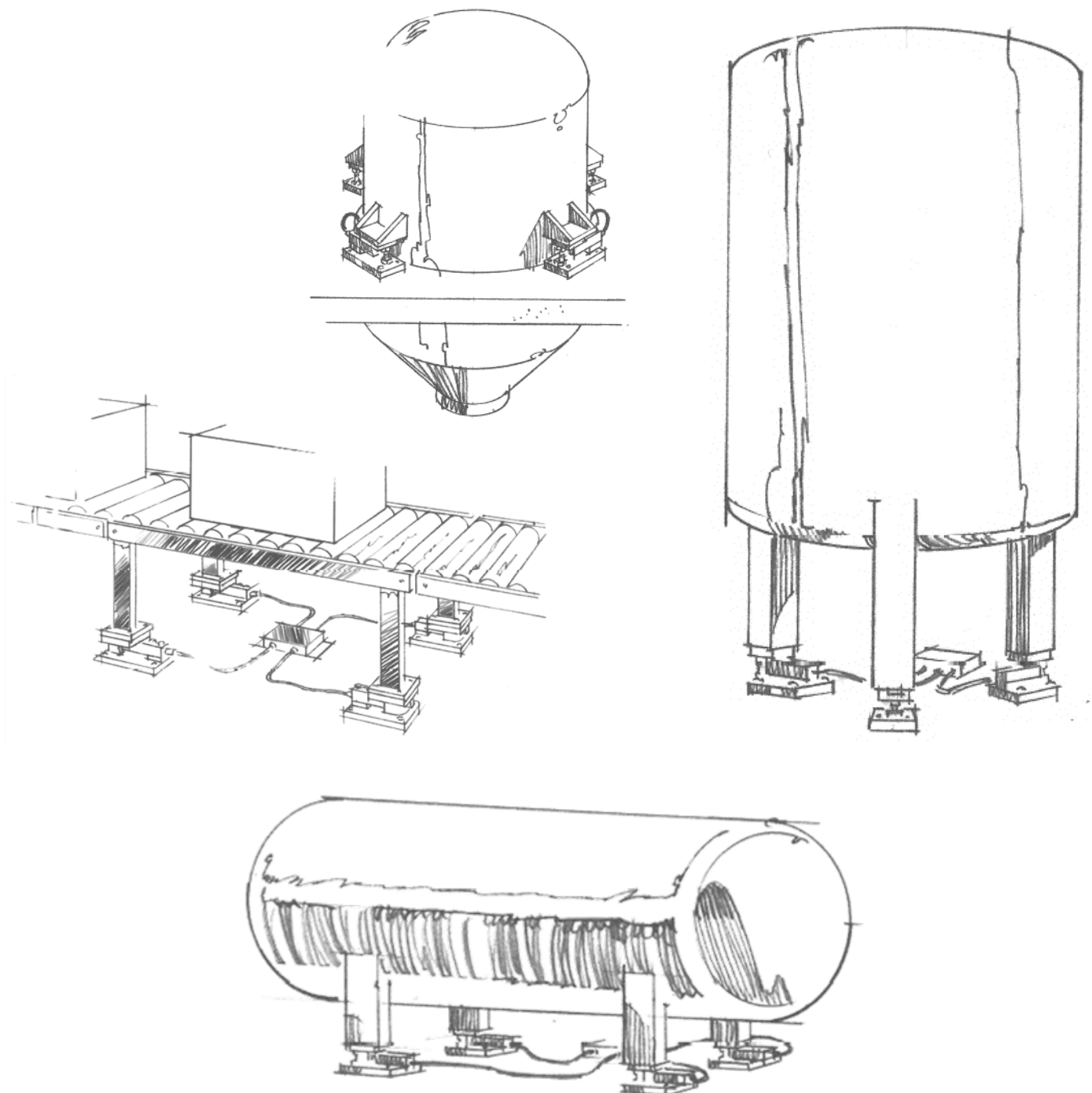

5.1.2. Tensile mode

In the tensile mode, the vessel is suspended from one or more load cells. If a suitable structure for a tensile application is available, it is usually easier, and less costly to hang the vessel (up to 10 tonnes.). For larger capacity vessels, it is more cost-effective to provide an adequate base for compression weighing.

- In theory, suspending a vessel from a single load cell may be the ideal solution, but such installations are not usually feasible.
- Three or four point of supports are the most commonly used configurations.
- To help implement the system, SCAIME provides ball joints suited to its S-type load cells.

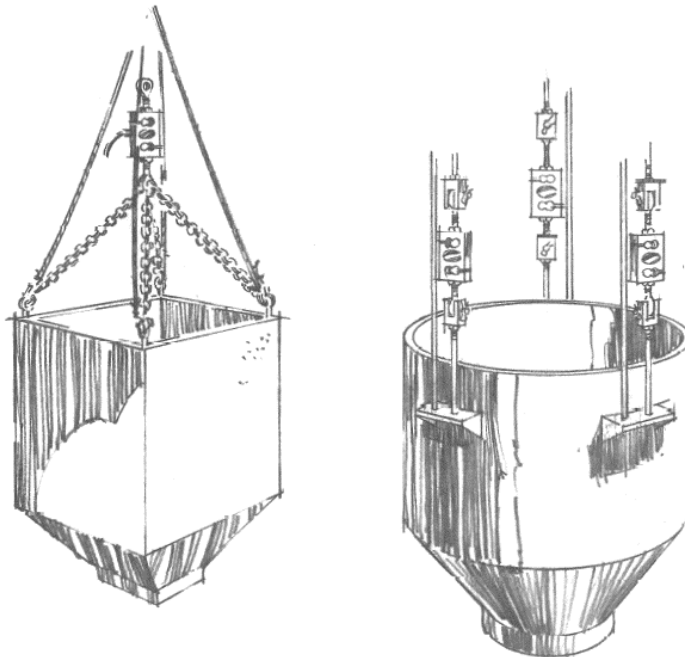

5.2. Compression mounting kits

Mounting kits allow you to convert any type of structure into scales. These kits can be integrated into a new structure or added to an existing structure.

Compression mounting kits are suitable for most weighing applications in conveyors, vessels, hoppers, tanks or silos. They are bolted directly to the ground or to the beams of the structure. The vessel or other load receptor will be secured on top of the mounting kits.

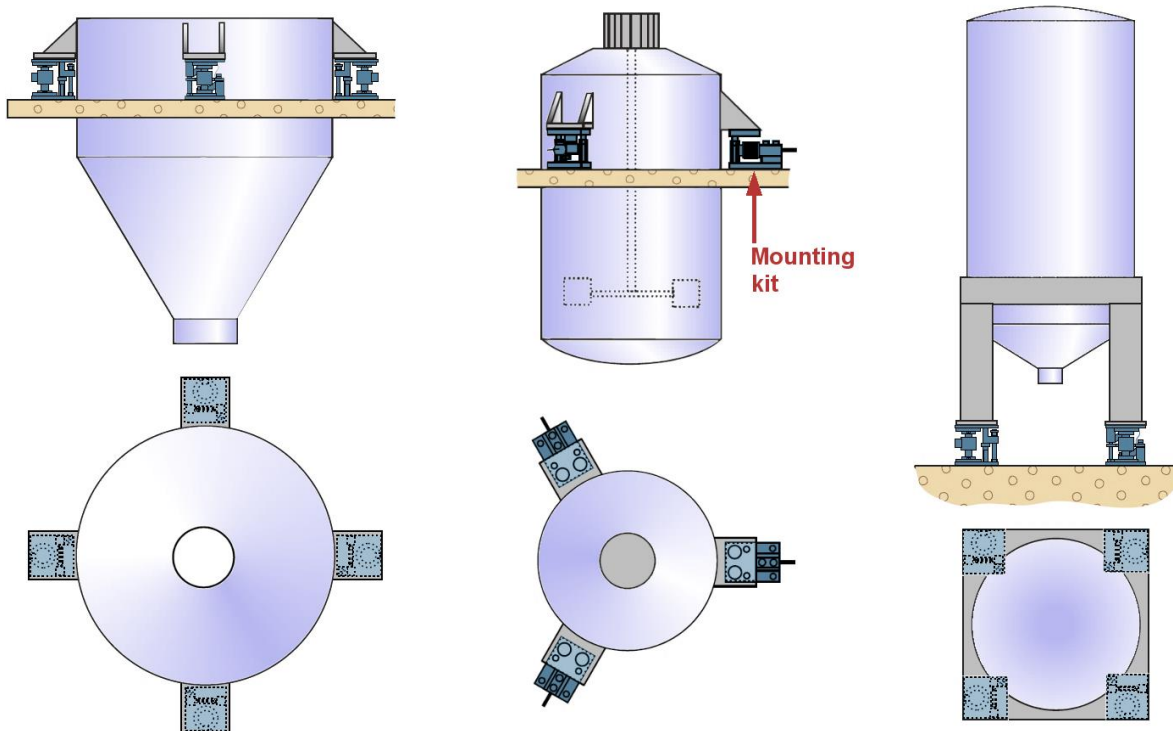

Tanks weighing with compression mounting kits

The aim of a mounting kit is to facilitate the implementation of the load cell while protecting its performance during use.

Typical mounting kits include a top plate (which receives the load), a base plate (bolted to the floor) and a device for transmitting the load to the load cell. This device is essential in eliminating unwanted forces and must be adapted to the application and to the required accuracy.

Some kits may offer additional equipment:

- Lift-off prevention device to prevent the vessel from tipping over.
- Stop to limit the movement of the structure.
- Stabilising rod to absorb unwanted side forces.
- Elastomer damper to absorb shocks and vibrations.

The following paragraphs show these systems for the main SCAIME mounting kits.

5.2.1. STABIFLEX mounting kit

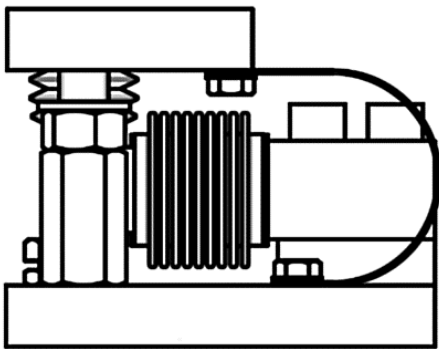

▲ STABIFLEX for F60X load cell

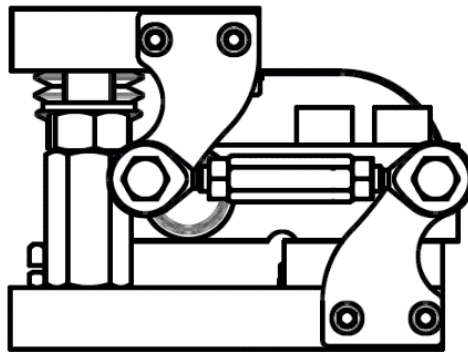

▲ STABIFLEX with restraint device for SK30X load cell

The STABIFLEX mounting kit is a self-centring mounting system which includes a ball and cup device that offers the best weighing results for a wide variety of applications.

The kit is also equipped with two stops limiting vertical and horizontal movements of the upper plate (load receptor). These devices act as a lift-off prevention tool and as a protection against accidental horizontal forces.

- ▶ **The STABIFLEX kit can be used for static or dynamic applications, in the presence of horizontal forces, flexible pipe connections, with thermal contraction/expansion, and when the application requires high accuracy.**

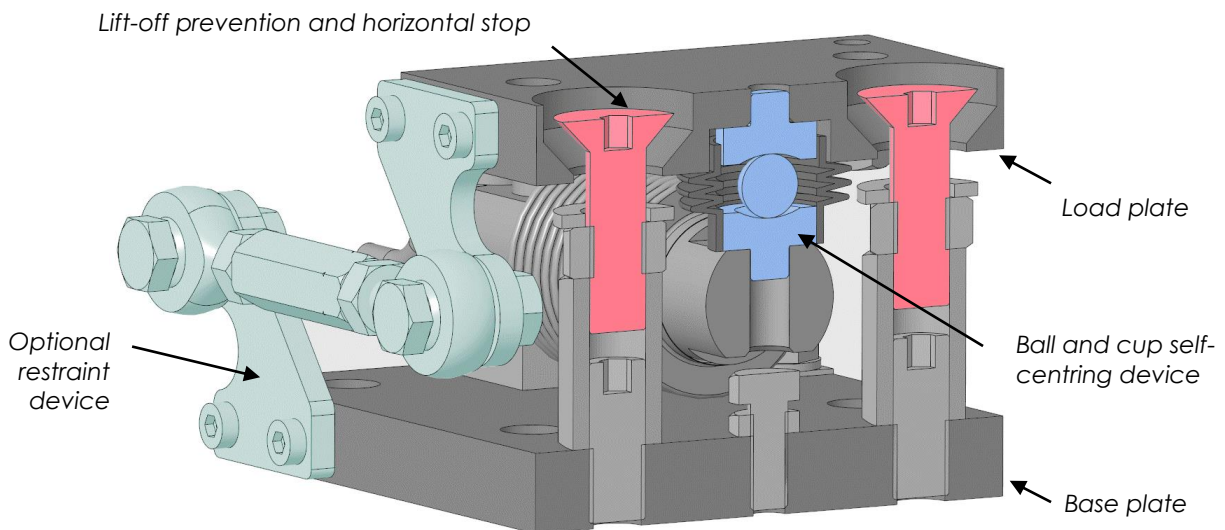

▲ Cross-section of a STABIFLEX kit for a F60X load cell

The Kit can be equipped with a restraint device to avoid unidirectional horizontal movements. The stay rod includes ball joints with adjustable ends that connect the top plate (load receptor) to the base plate.

Stay rods can be used in three cases:

1. To stabilise a dynamic system when weighing is to take place while a large mixer is in operation.
2. To stabilise a system when stabilisation time is critical, for example for a high speed conveyor.
3. To stabilise a dynamic system and protect against the failure of connected pipes.

▶ **Stay rods degrade the metrological performances of low capacity load cells. Their use should be avoided with load cells with a capacity below 100 kg.**

5.2.2. RUBBERKIT and ISOFLEX mounting kits

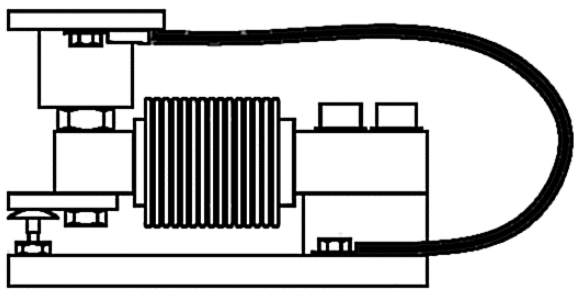

▲ RUBBERKIT for F60X load cell

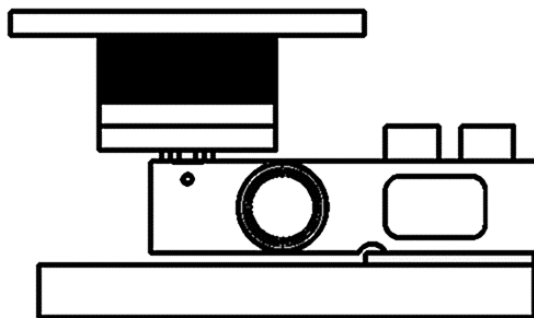

▲ ISOFLEX for SK30X load cell

RUBBERKIT and ISOFLEX mounting kits are rigid mounting kits. The load transmission device is a swivelling bolt connection between the load receptor and the load cell. These kits include elastomer for damping shocks and vibrations.

▶ **The RUBBERKIT and ISOFLEX kits can be used for static or dynamic applications, in the presence of horizontal forces, pipe connections but with a low thermal contraction/expansion.**

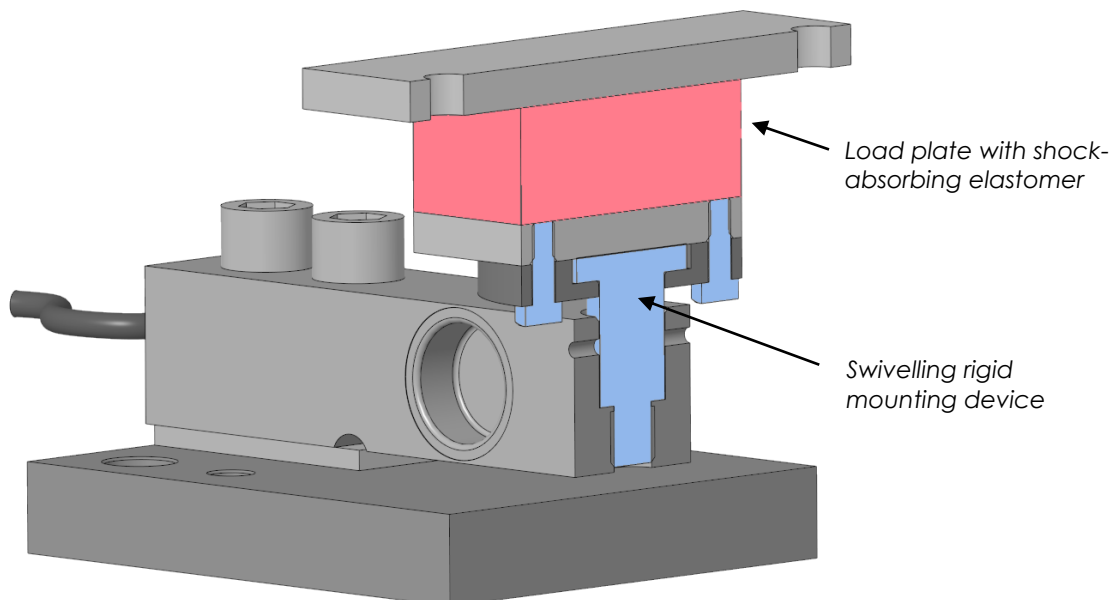

▲ Cross-section of an ISOFLEX kit for SK30X load cell

5.2.3. QUICKFIT mounting kit

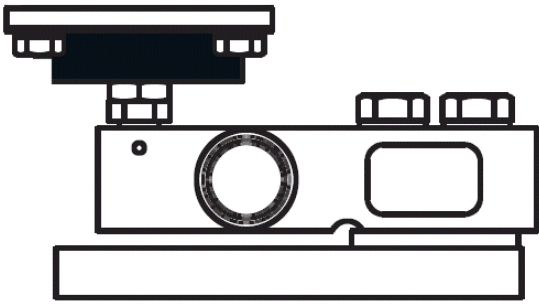

◀ QUICKFIT for SK30X load cell

The QUICKFIT mounting kit is a self-centring mount providing a precise load input for high accuracy in a wide variety of applications.

The load transmission device is a pillar with a spherical end held and hinged in the load cell. This pillar is bolted onto a height adjustable load plate incorporating an elastomer system to absorb side forces.

- ▶ **The QUICKFIT kit can be used for static or dynamic applications, in the presence of horizontal forces, pipe connections with thermal contraction/expansion.**

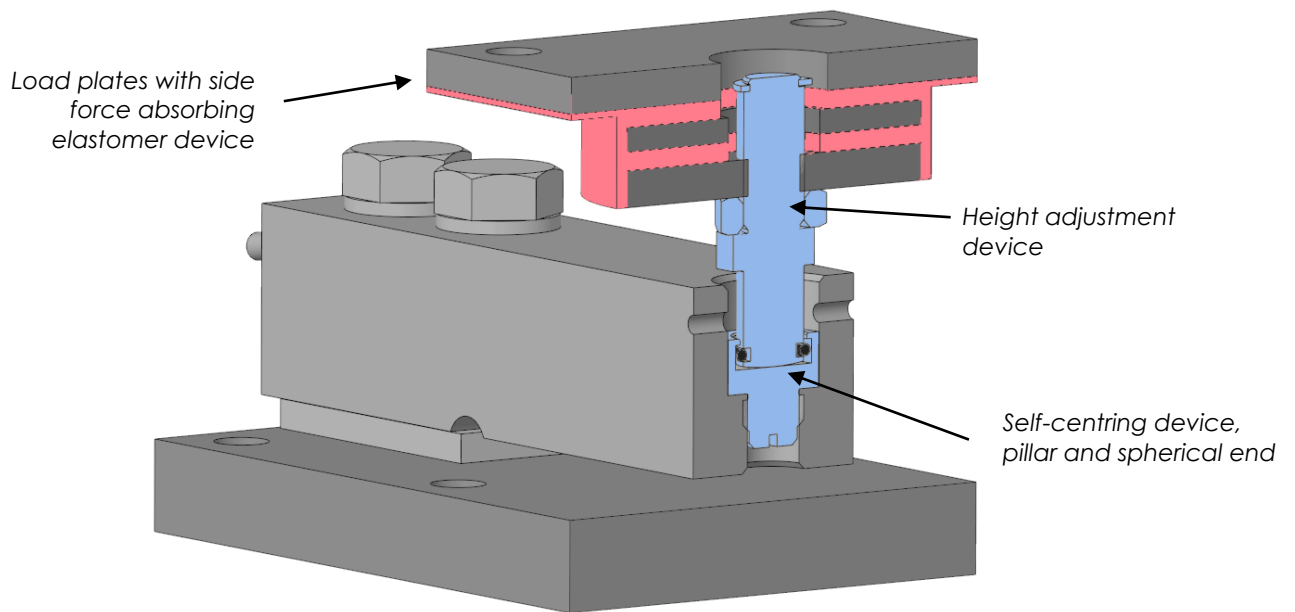

▲ Cross-section of the QUICKFIT kit for SK30X load cell

5.2.4. SILOSAFE mounting kit

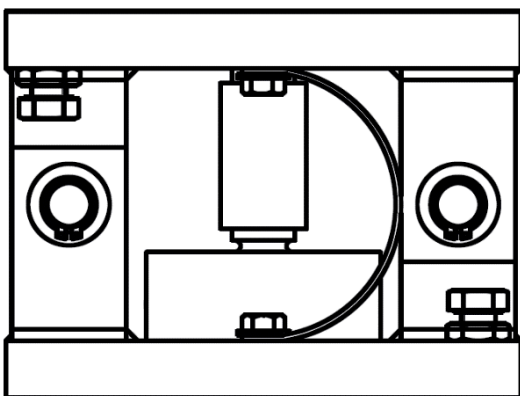

▲ SILOSAFE for R10X load cell

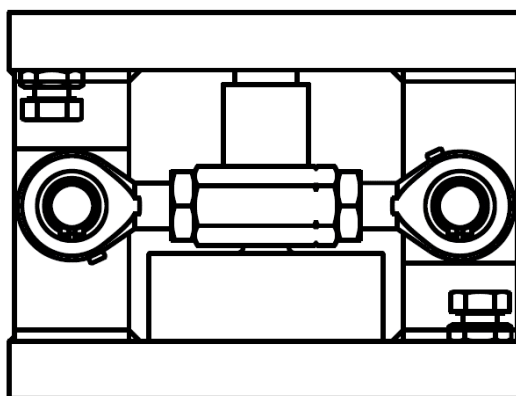

▲ SILOSAFE with restraint device for R10X load cell

The SILOSAFE mounting kit is an assembly with a self-centring pendulum load transmission device with two spherical ends. This device provides the best weighing results for all high capacity applications.

The kit is also equipped with two axes used as stops that limit lateral multidirectional movements of the upper plate (load receptor). These extremely robust devices act as a lift-off prevention tool and as a protection against accidental horizontal forces.

This mounting kit is also designed for safety, in the event of a load cell failure, with the pillar of the load plate resting on that of the base plate.

- ▶ **The SILOSAFE kit can be used for static or dynamic applications, in the presence of horizontal forces, flexible pipe connections, with thermal contraction/expansion, and when the application requires a high level of security.**

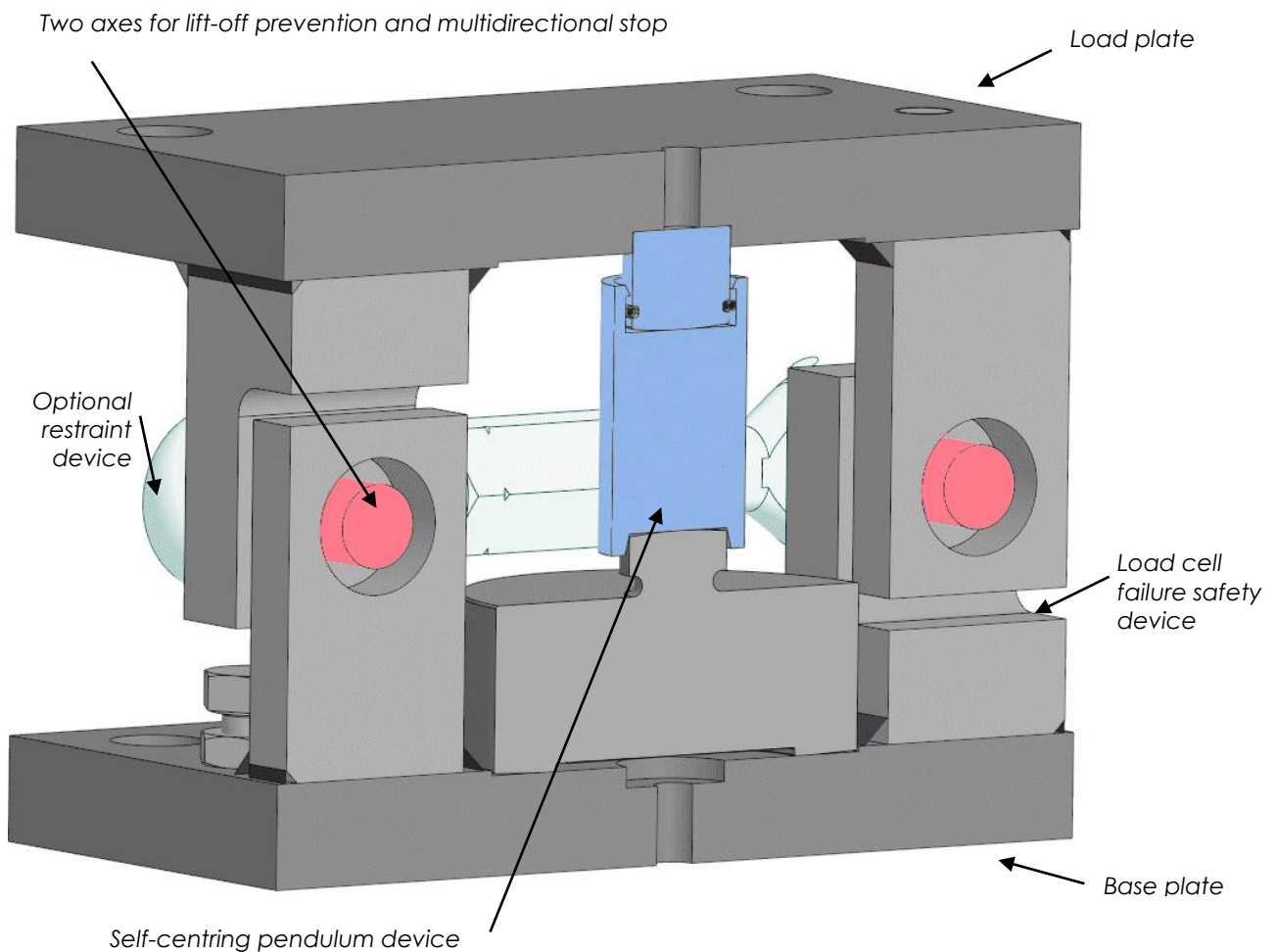

▲ Cross section of a SILOSAFE kit for R10X load cell

The Kit can be equipped with one or two restraint devices to avoid unidirectional horizontal movements. The stay rod includes ball joints with adjustable ends that connect the top plate (load receptor) to the base plate via the lift-off prevention axis.

Stay rods can be used in three cases:

4. To stabilise a dynamic system when weighing is to take place while a large mixer is in operation.
5. To stabilise a system when stabilisation time is critical.
6. To stabilise a dynamic system and protect against the failure of connected pipes.

5.3. Weighing system performance

Accuracy, resolution, and repeatability are basic concepts used to measure a weighing system's performance.

5.3.1. Resolution

Resolution is the smallest weight change that a digital weighing system can detect. Resolution is measured as the number of increments (intervals).

It makes no sense for an analogue load cell, it only depends on the ability of the system's electronics to detect a change in the load cell signal.

For many applications requiring measurement processing, such as digital filtering, determining measurement stability, calculating a weighing result or stopping weight filling, the weighing electronics must be able to handle a very small resolution, such as 0.01kg. However, this does not mean that the accuracy of the system is 0.01kg.

In legal metrology, in order not to mislead the user, the displayed result cannot exceed the accuracy. On the other hand, when processing the measurement and for carrying out various functions, the indicator or the transmitter uses a much higher internal resolution, generally 10X the display resolution.

5.3.2. Accuracy and repeatability

- **Accuracy** represents the difference between the weight displayed by the scales and the actual weight. Scales accuracy is generally measured from a recognised standard, such as test weights.
- **Repeatability** is the capacity of scales to display a uniform value each time the same load is weighed. This is especially important for filling applications, which require that the same amount of a material be used for each batch.

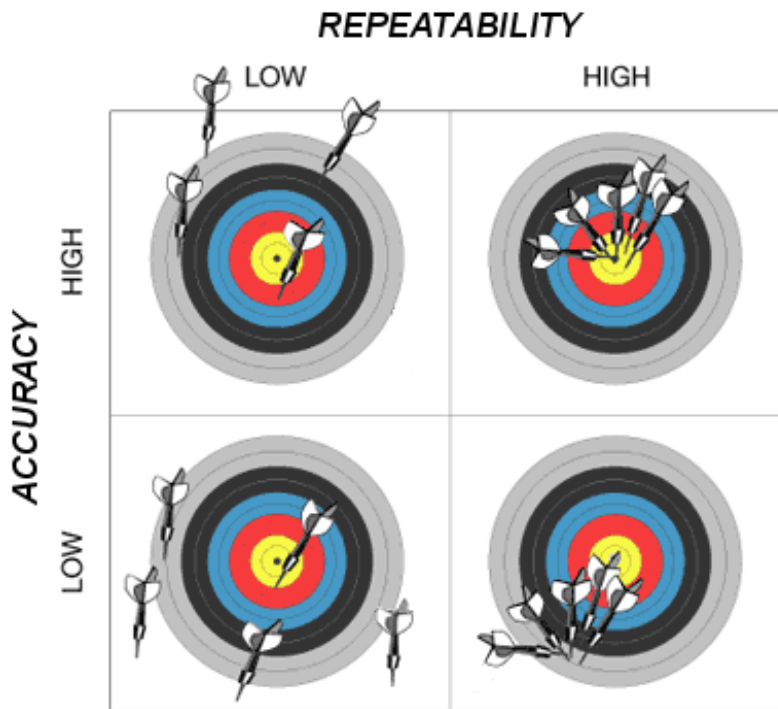

- ▶ **Repeatability and accuracy go hand in hand. You can have a repeatable system that is not accurate, but you cannot have an accurate system unless it is repeatable.**

5.4. How many load cells?

The number of load cells to support a vessel is usually dependent on the vessel's design.

The ideal situation is the use of 3 load cells. If a vessel is supported by 4 or more load cells, 3 or, in the worse case, only 2 load cells could bear the total weight. In this case, an overload situation on these cells might occur.

By measuring the output of every individual load cell, such a situation can be detected and corrected by placing shim plates underneath the least loaded cells.



- **The load cells should be positioned in such a way that each load cell will bear the same amount of weight.**

5.4.1. Force applied to the load cell

Load cells must resist to the total applied load in normal and exceptional conditions.

The maximum load cell capacity, C_{LC} must satisfy the following formula:

$$C_{LC} \geq \frac{Q \times (Tare + C_{LIVE})}{N}$$

Where:

- **Tare:** Tare or dead load (kg)
- **C_{live}:** Maximum load applied (kg)
- **Q:** Safety factor
- **N:** Number of load cells

5.4.2. Safety factor

There are no rules for defining the safety factor Q, which usually depends on environmental conditions:

- Eccentric load conditions
- The initial zero reset range (20% of the capacity)
- Shocks and dynamic load
- Wind forces
- Load receptor design

A few examples, for information:

| | Q |
|------------------------------------|------------|
| 4 load cells platform scale | 1.8 |
| Indoor vessel | 1.3 |
| Vessel with a mixer | 1.7 |
| Weighbridge | 2 |
| 1 load cell platform scale | 1.4 |

5.5. Weighing system capabilities

The compatibility of a combination of load cells and an indicator or a transmitter must be assessed when designing a system with a desired resolution.

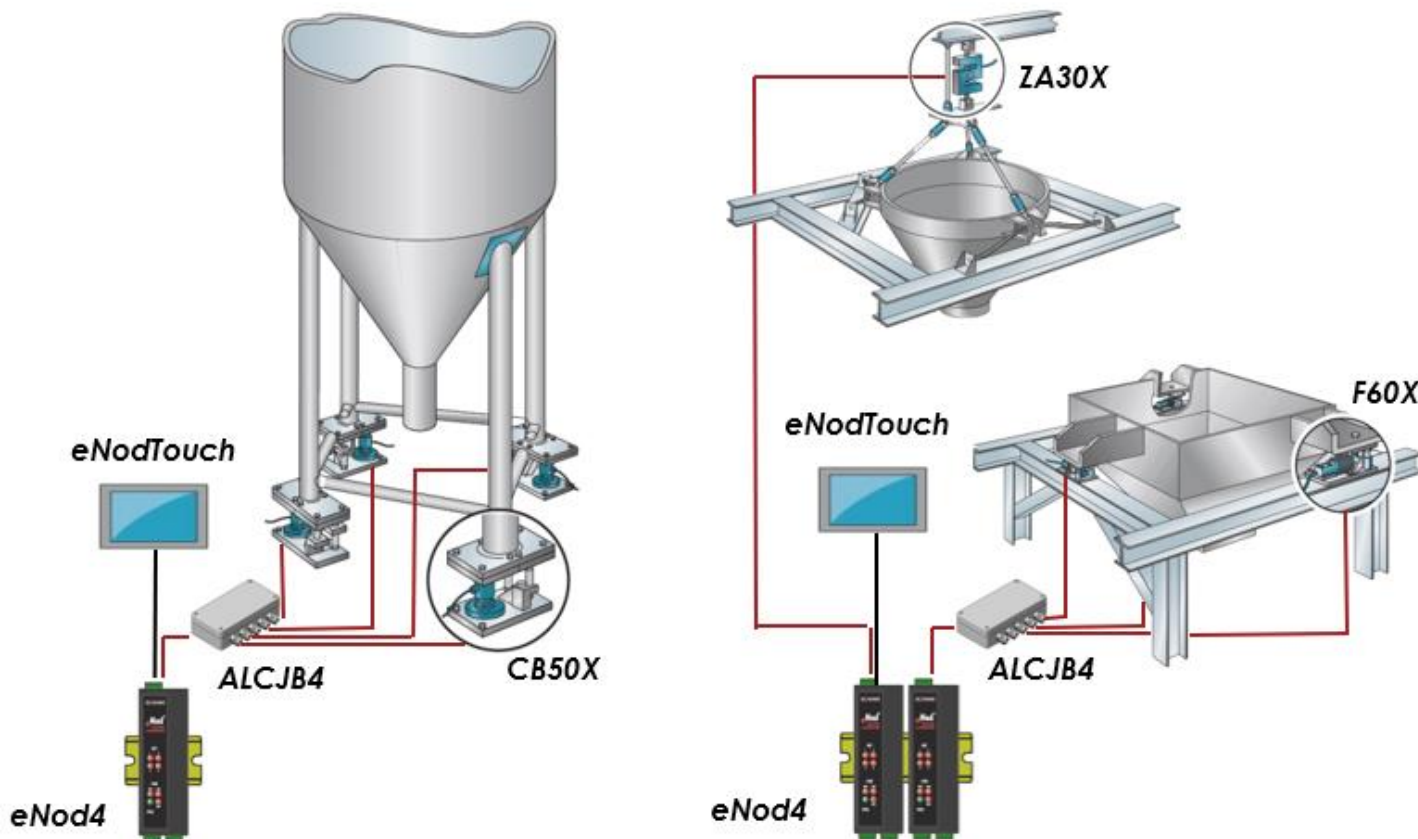

▲ Examples of weighing systems with 1, 3 or 4 load cells

5.5.1. System resolution

The desired resolution for the system can be determined using the following formula:

$$\text{Signal par échelon } (\mu\text{V}) = \frac{\text{Echelon} \times \text{Sensibilité capteur (mV/V)} \times \text{Tension alim (V)} \times 1000}{\text{Capacité nominale capteur} \times \text{Nombre de capteurs}}$$

- The signal by increment calculated must be greater than the minimum allowed for the indicator (as given in its technical datasheet).

Example

Take a vessel with four 5000 kg load cells (2 mV/V) attached to an eNod4 weighing transmitter.

You want to be able to weigh up to 15,000 kg at 2 kg increments (7,500 increments displayed).

Use the formula to determine the signal per increment:

$$\frac{2 \text{ kg} \times 2 \text{ mV/V} \times 5 \text{ VDC} \times 1000}{5000 \text{ kg} \times 4} = 1 \mu\text{V}$$

The minimum acceptable signal for eNod4 is **0.5µV** microvolt per increment. Since the 1 µV signal derived from the formula is greater than 0.5 µV, you should be able to display 2 kg increments.

5.5.2. Excitation voltage

In a measuring chain, the excitation voltage provided by the transmitter must be suitable as a supply to the load cells.

The resistance of the weighing system is calculated: $Z = \frac{R_{LC}}{N} (\Omega)$

Where:

- **R_{LC}** : load cell input resistance
- **N**: number of load cells

The excitation voltage must provide an intensity: $I_{ALIM} = \frac{U_{ALIM}}{Z}$

Where:

- **U_{exc}** is the load cell excitation voltage

- ▶ **Verify that $Z > R_{min}$ (Minimum indicator impedance), or $I_{exc} < I_{max}$ (Maximum intensity of the indicator)**

5.6. *Determination of the accuracy of the system*

The first question that the designer of a weighing system must ask: what accuracy can the weighing system achieve?

There is no simple answer to this as many factors may influence the accuracy and repeatability of a weighing system.

- **Load cell factors:** Type, number, capacity, characteristics (see §4)
- **Mechanical factors:** Shape of the vessel, support structure, piping
- **Environmental factors:** Wind, temperature, vibration
- **Calibration**

The easiest first step is to determine the maximum accuracy attainable with the selected load cells and examine the various influencing factors that apply to try to minimise their effects.

To determine the accuracy attainable by a weighing system, the following elements must be known:

- The weighing capacity of the system (**C_{LIVE}**): is the maximum load applied to the system, excluding dead load (empty tare).
- Dead load or empty tare (**Tare**): This is the load applied to the sensors when they are empty (weight of the weighing platform, weight of an empty vessel)
- Number of cell loads used (**N**)

The designer of the weighing system must also analyse the requirements for its application: commercial or internal use, measurement accuracy, repeatability or stability or fast acquisition.

- ▶ **To help the designer in this analysis, the assessment guide below summarises the main parameters to be taken into account for the design of the weighing system, according to the application and accuracy required.**

5.6.1. Weighing system analysis guide

| System data | | | | |
|---|--|---|--|---|
| Required accuracy | High | Average | Low | Detection |
| System accuracy (% of the capacity) | ±0.01 to 0.03 | ±0.03 to 0.1 | ±0.1 to 0.5 | > ±0.5 |
| Application | Weight control | | | |
| | Dosing - Filling | | | |
| | Mixing - Formulation | | | |
| | | Transfer of material | | |
| | Level in a storage tank | | | |
| Weighing system equipment | | | | |
| Load cell certification | OIML C6, C3 | OIML C3 | OIML D1, not certified | Not certified |
| Load cell combined error | ±0.008 to 0.02 | ±0.02 to 0.05 | ±0.05 to 0.2 | ±0.2 or less |
| Load cell operating range (% rated capacity) | ≥50 | ≥30 | ≥30 | ≥20 |
| Mounting kit load | Ball and cup, pendulum | Ball and cup, pendulum, sliding | Ball and cup, pendulum, sliding, rigid | Ball and cup, pendulum, sliding, rigid Use of pivots |
| Fake load cells or pivots | - | - | - | For liquids/gases |
| Installation parameters | | | | |
| Pipe connections | Flexible | Flexible | Flexible or rigid | Flexible or rigid |
| Structure | Rigid Isolated from environmental factors | Rigid Isolated from environmental factors | Rigid | Rigid |
| Environmental parameters | | | | |
| Load cell temperature range | Within the rated range | Within the rated range | Within the rated range | Within the operating range |
| Vibrations | No | Limited, use of vibration damping | Limited, use of vibration damping | Use of vibration damping |
| Wind, drafts | No, indoor application | Within the limits of the mounting kit | Within the limits of the mounting kit | Within the limits of the mounting kit |
| Calibration | | | | |
| Procedure | Test weights, substitution of material | Test weights, substitution/transfer of material | Substitution/transfer of material | Theoretical |
| Electronics | | | | |
| Electronic certification | OIML 6000d | OIML 3000d | - | - |
| Advanced digital filter | Yes | If needed | If needed | No |

5.6.2. Determination of accuracy from OIML R60 characteristics

To assess the accuracy (legal metrology), the OIML R60 characteristics of the load cells are used.

- Maximum number of verification intervals: n_{\max}
- Minimum verification interval: $V_{\min(LC)}$

Prior to this, we must check the cell load capacity is compatible with the application.

We calculate the minimum interval for the system in relation to the minimum interval for the load cells:

$$V_{\min(sys)} = V_{\min(LC)} \times \sqrt{N}$$

We also calculate the interval for the system in relation to the maximum number of intervals for the load cells and the weighing capacity of the system:

$$e_{(sys)} = \frac{C_{LIVE}}{n_{\max}}$$

We then check the compatibility of the two results:

- ▶ **If $e_{(sys)} \geq V_{\min(sys)}$, the result $e_{(sys)}$ (rounded up, multiple of 1, 2 or 5) can be chosen as an interval for the system**
- ▶ **Si $e_{(sys)} \leq V_{\min(sys)}$, the result $V_{\min(sys)}$ (rounded up, multiple of 1, 2 or 5) can be chosen as an interval for the system**

Example

Let's take our vessel with a capacity of **15,000 kg** with **four 5,000 kg load cells** connected to an eNod4 weight transmitter.

The capacity of the vessel is **15,000 kg**.

We want to measure the weight according to legal metrology and need the best possible interval for this system.

The load cell data is: **$n_{\max} = 3000$ and $V_{\min} = 0.5$ kg**

The calculation for the minimum intervals for the system is as follows:

- **$V_{\min(sys)} = 0.5 \times \sqrt{4} = 1$ kg**

The interval calculation in relation to the maximum number of intervals and the capacity is:

- **$e_{(sys)} = 15,000 / 3,000 = 5$ kg**

- ▶ **If the user prefers using the full capacity of the vessel (15,000 kg), then the best possible interval for the system will be $e_{(sys)} = 5$ kg**
- ▶ **If the user prefers higher accuracy, the vessel must not be used to its full capacity:**
 - Intervals of 1 kg for a usable capacity of 3,000 kg
 - Intervals of 2 kg for a usable capacity of 6,000 kg

5.7. Load cell location

Load cells are usually mounted:

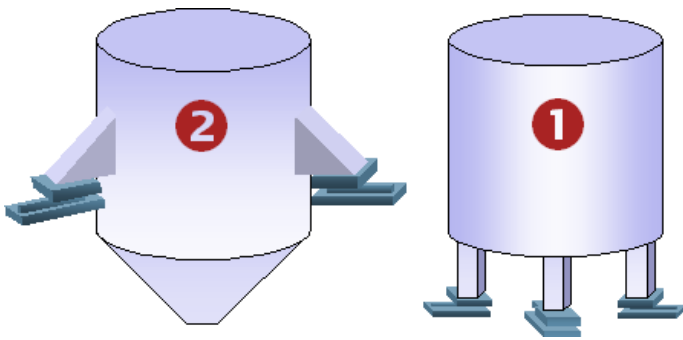

- ❶ Under the vessel's legs.
- ❷ Between a gusseted bracket and a mezzanine floor.

Mounting the device under the legs is perfectly acceptable. However, the second option is the best, due to the natural stability provided by a low centre of gravity.

A few examples of load cell locations

▼ Vessel with a mixer

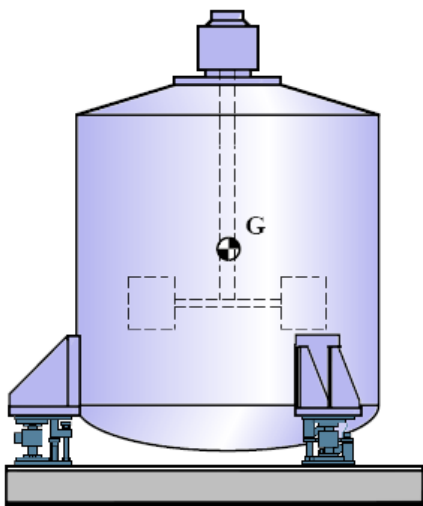
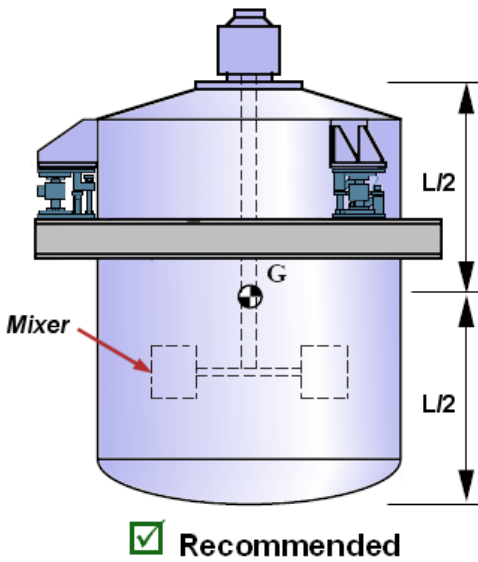

▼ Eccentric vessel with variable centre of gravity

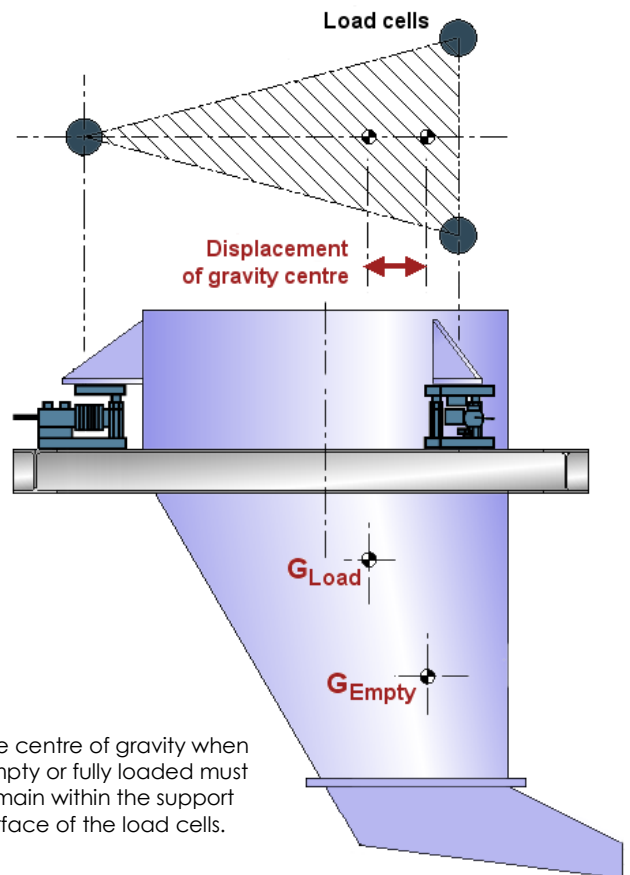

Plan the layout of the load cells so that they can support more or less equal weights. Check the mounting kits are correctly oriented in relation to one another. The orientation of the weighing module depends on its design and may be affected by the system's stabilisation options.

Examples of mounting kit locations - vessel on 3 and 4 legs

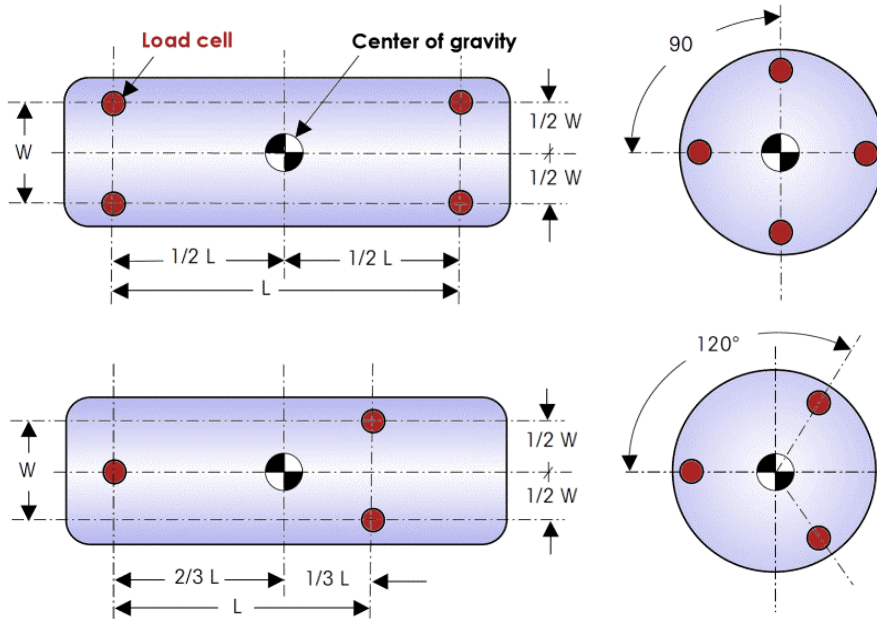

- Under these normal weighing conditions, all the load cells should be subjected to a downward force.

Examples of orientation of mounting kits with restraint devices

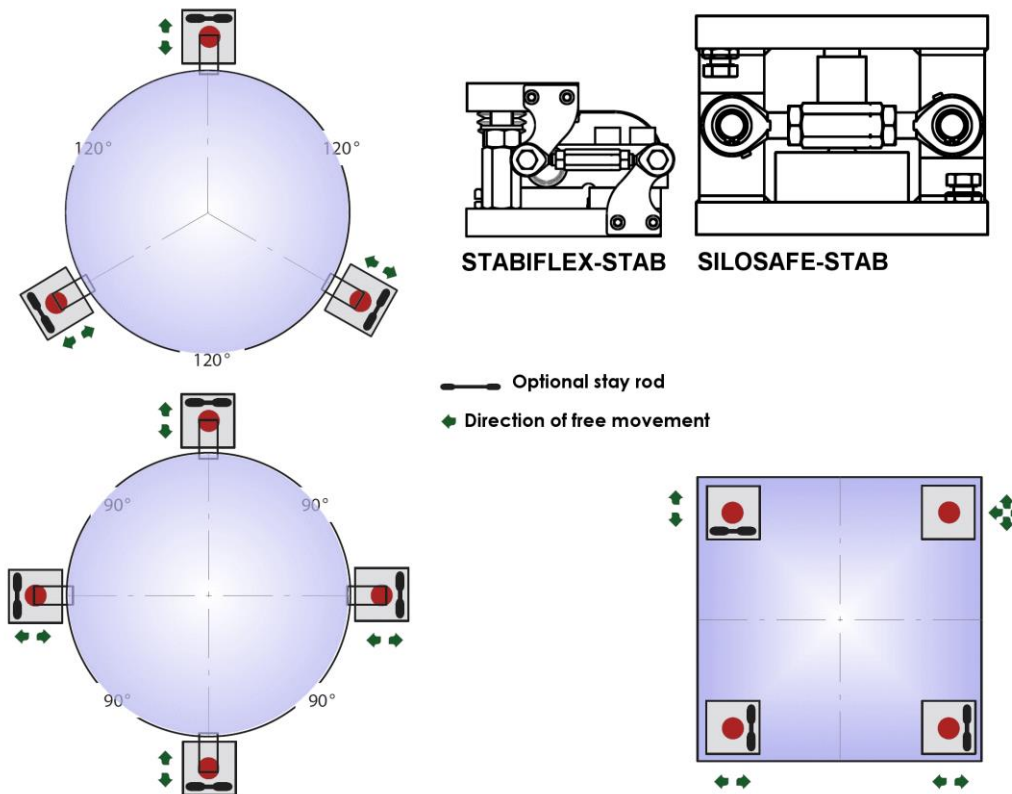

- Restraint devices must be oriented so that undesirable horizontal forces are eliminated, while allowing thermal expansion for the structure.

5.8. Load introduction

Load cells equipped with strain gauges are sensitive enough to detect very small weight variations. The aim is to make sure that they only react to the weight you want to measure, not to other forces. To get accurate weight readings, you must carefully control how and where weight is applied.

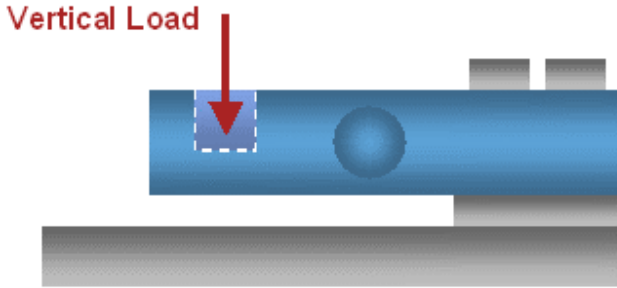

- A load cell should be installed so that the load is always applied vertically throughout the entire weight range.
- To do so, the load cell support must be level, parallel, and rigid.

Loading force issues

When the load cell is not installed correctly, several types of forces can affect its accuracy:

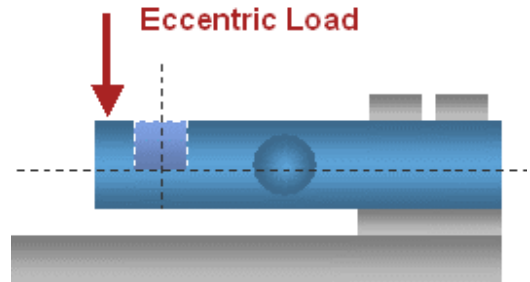
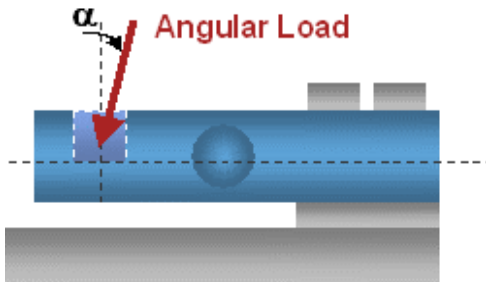

▲ **Angular loading** occurs when a force that is not perfectly vertical is applied to a load cell.

▲ **Eccentric load** occurs when a vertical force is applied to a load cell at a point other than its centre line. This problem can be caused by thermal expansion.

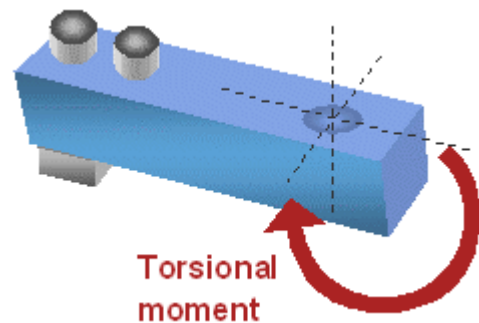
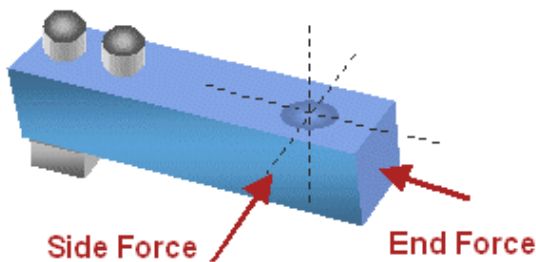

▲ **Side and end loading** occur when horizontal forces are applied to the side or end of a load cell. They can be caused by thermal expansion, a misalignment, or by movement due to dynamic loading.

▲ **Torsion** occurs when a side force twists a load cell. It can be caused by structural deflection, system dynamics, thermal movement, or misalignments.

Angular error

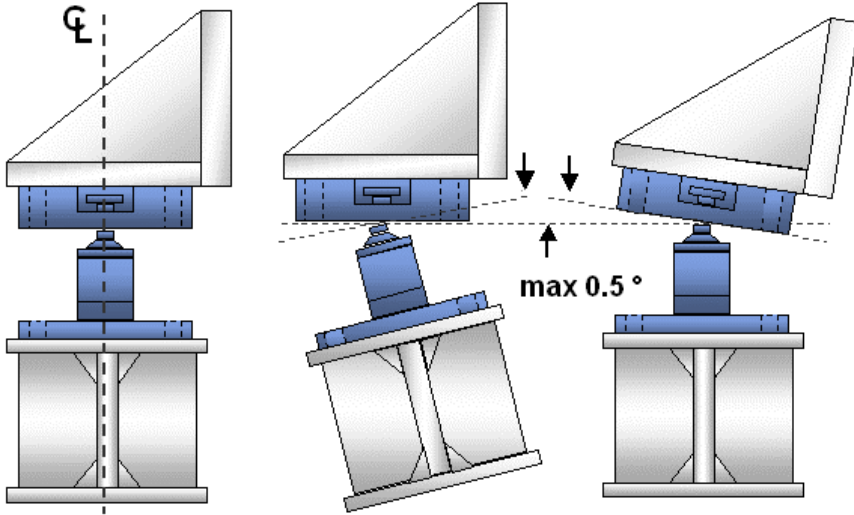

- Top support and base support should be aligned and horizontal.
- Top support and base support should not deflect by more than 0.5°.
- The centre line (CL) of the load on the load cell should align to the centre line of the support to prevent structure deflection.



- The mounting kits must be on the same plane, within ± 3 mm.
- The top and base plates should be level, within ± 0.5 degrees.
- Top and base plates should not deform more than ± 0.5 degree when the rated capacity is applied.
- The structure should deform evenly.

$$\text{Erreur de mesure} = 1 - \frac{1}{\cos(\alpha)} \times \text{charge}$$

5.9. Structural integrity

The performance of a load cell mainly depends on its ability to deform under highly reproducible conditions when a load is applied or removed.

5.9.1. Support structure design

Metal support structures tend to bend or deflect as the amount of weight placed on them increases. Too much deformation can affect the accuracy of the weighing system on a vessel.

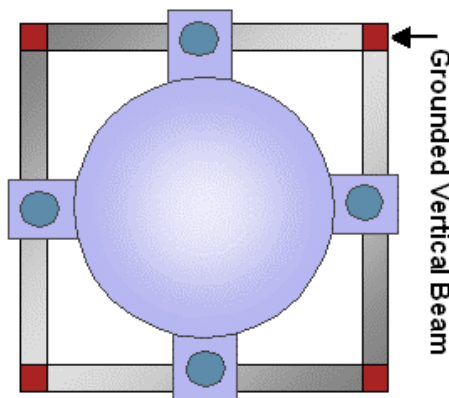

Not Recommended

▲ Mounting load cells at the centre of the support beams will cause high deformation at high loads.

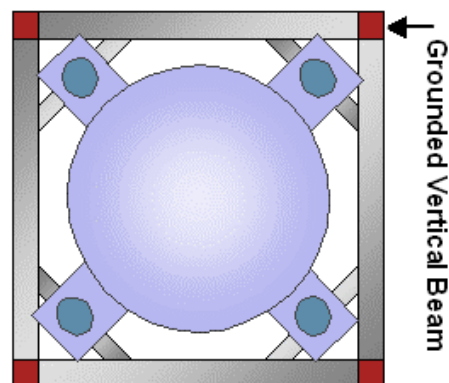

Recommended

▲ To reduce the deformation, mount load cells next to vertical posts and support each load cell with identical beams.



- Reinforcing the support beams is recommended to minimise deformation.

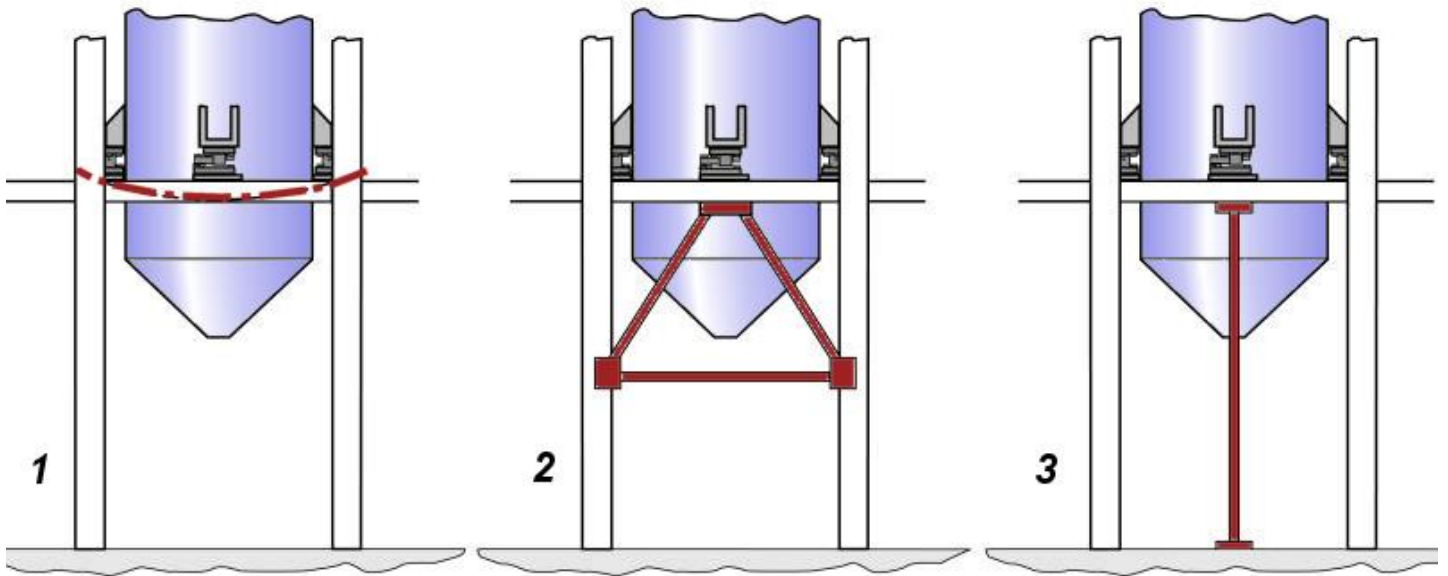

- Figure 1 shows how a support beam can deform when a weighing module is mounted at mid-span. If this type of layout cannot be avoided, strengthen the support beams to minimise deformation.
- Figure 2 and 3 show typical strengthening methods.

Example of a method used to mount load cells near grounded vertical posts

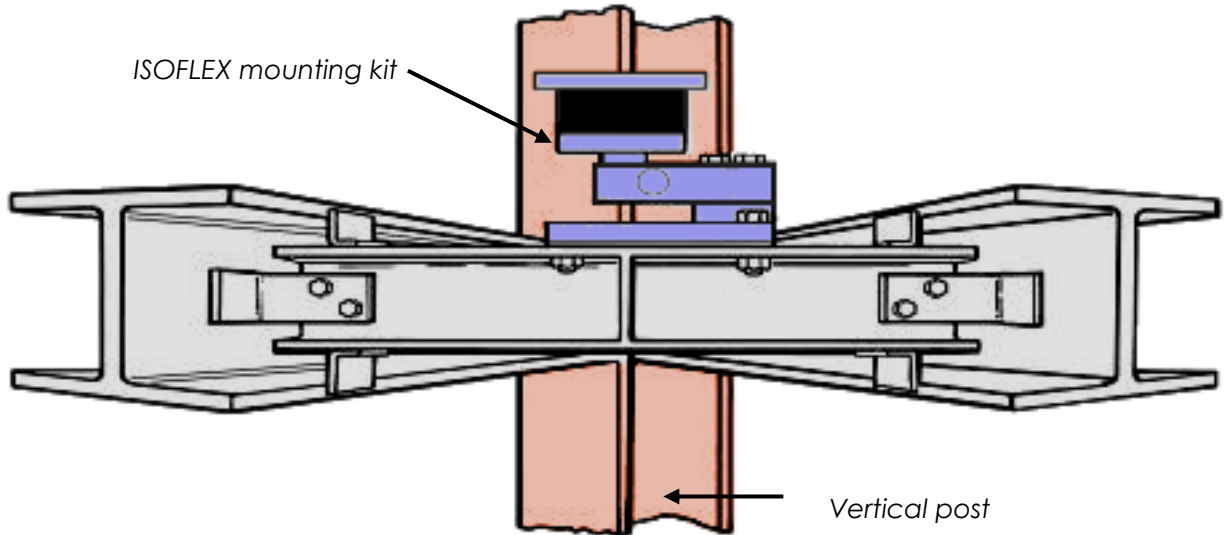

5.9.2. Structure deformation

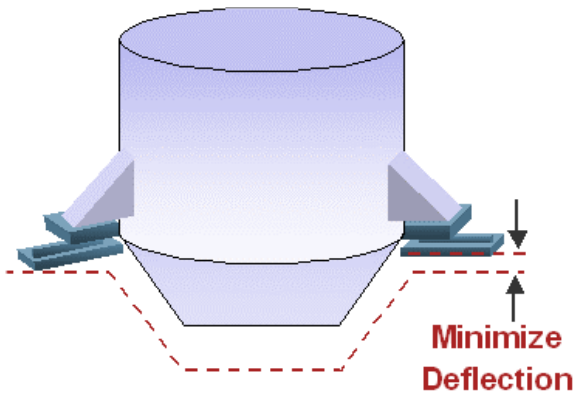

- The weighing structure of a vessel should deform as little as possible, and any deformation should be uniform at each supporting point.
- Support structures and the base of the foundation should be horizontal (± 0.5 degrees) and on the same plane.



- Add stiffeners and gussets to prevent the beams from twisting when subjected to a load.

Examples of support strengthening

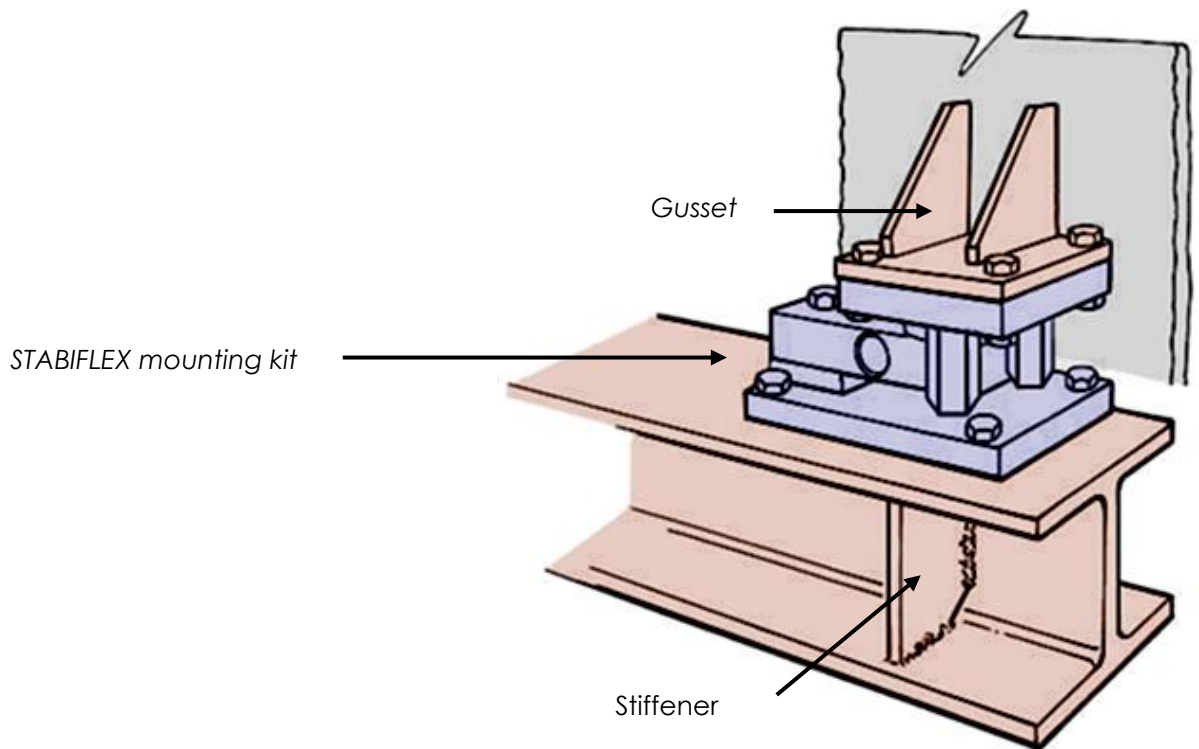

Example of reinforcements on the vertical posts

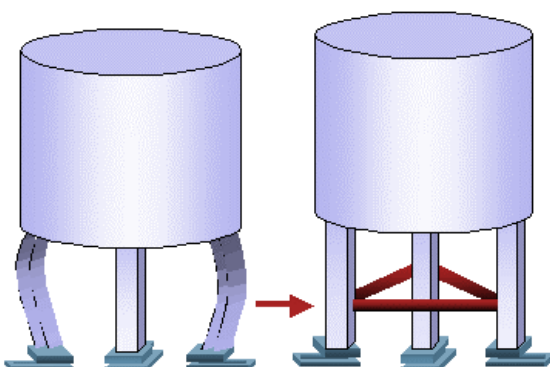

- In certain cases, the legs of a vessel will warp under its weight. If the deformation is great enough to affect weight measurements, the legs of the vessel should be braced to keep them rigid.
- Use the same support beam sizes to avoid uneven deformation.

5.9.3. Interaction between two vessels

Tanks sharing the same support structure will have an effect on each other's measurement performances. Any movement or disturbance of one tank is easily transferred to the second.

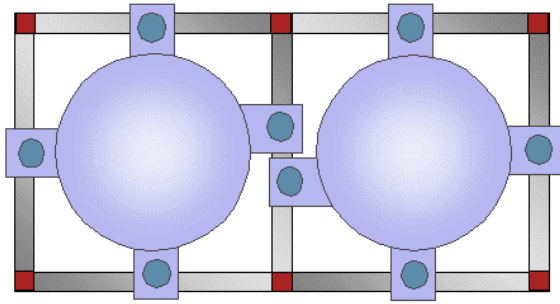

 **Not Recommended**

- The worst choice is to mount the load cells at the mid-span of a horizontal beam, with the two tanks sharing a common support structure. This results in a deformation and an interaction between the two tanks.

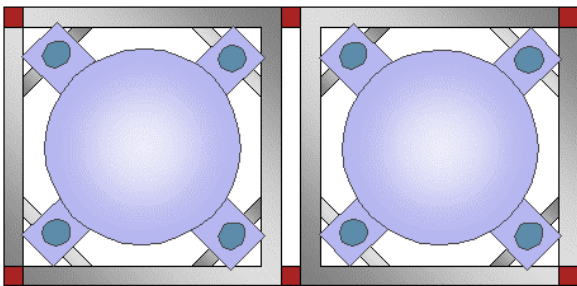

 **Recommended**

- The best solution is to mount the load cells near vertical posts, with a separate support structure for each tank.

5.10. *Lift-off prevention devices*

Accidental forces such as wind or from seismic events can be strong enough to overturn certain vessels. In the event of such a risk, mounting kits incorporating lift-off prevention devices should be used or, failing this, external devices that can resist to these overturning forces.

- The designer of the weighing system must check that the resistance of the device is sufficient for the application (wind force, seismic area).
- This safety device should not be used in normal operating conditions.



- **The resistance of the lift-off prevention device must be compatible with the application.**
- **An external lift-off prevention system must be installed if the mounting kit does not include such a safety device.**

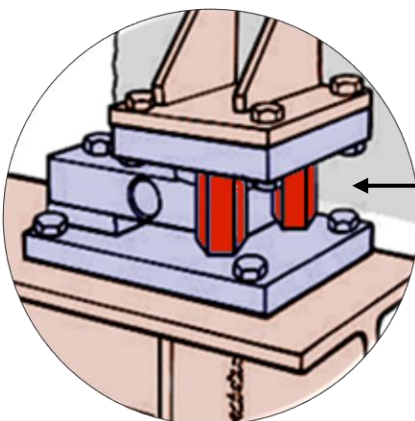

Lift-off prevention device integrated in the STABIFLEX mounting kit.

5.11. Stabilisation devices

When selecting the most suitable mounting kit for a given application, consider how the load will be applied to the load cells:

- **Static load:** Applications in vessels or hoppers are often subjected to a static load. In this case, horizontal forces transferred to the load cells are low: **The use of restraint devices is generally not needed.**
- **Dynamic load:** Applications such as conveyors, or tanks equipped with powerful mixers can be subjected to a dynamic load. In this case, horizontal forces can be transferred to the load cells: **The use of restraint devices is therefore recommended.**

5.11.1. Applications that do not require restraint devices

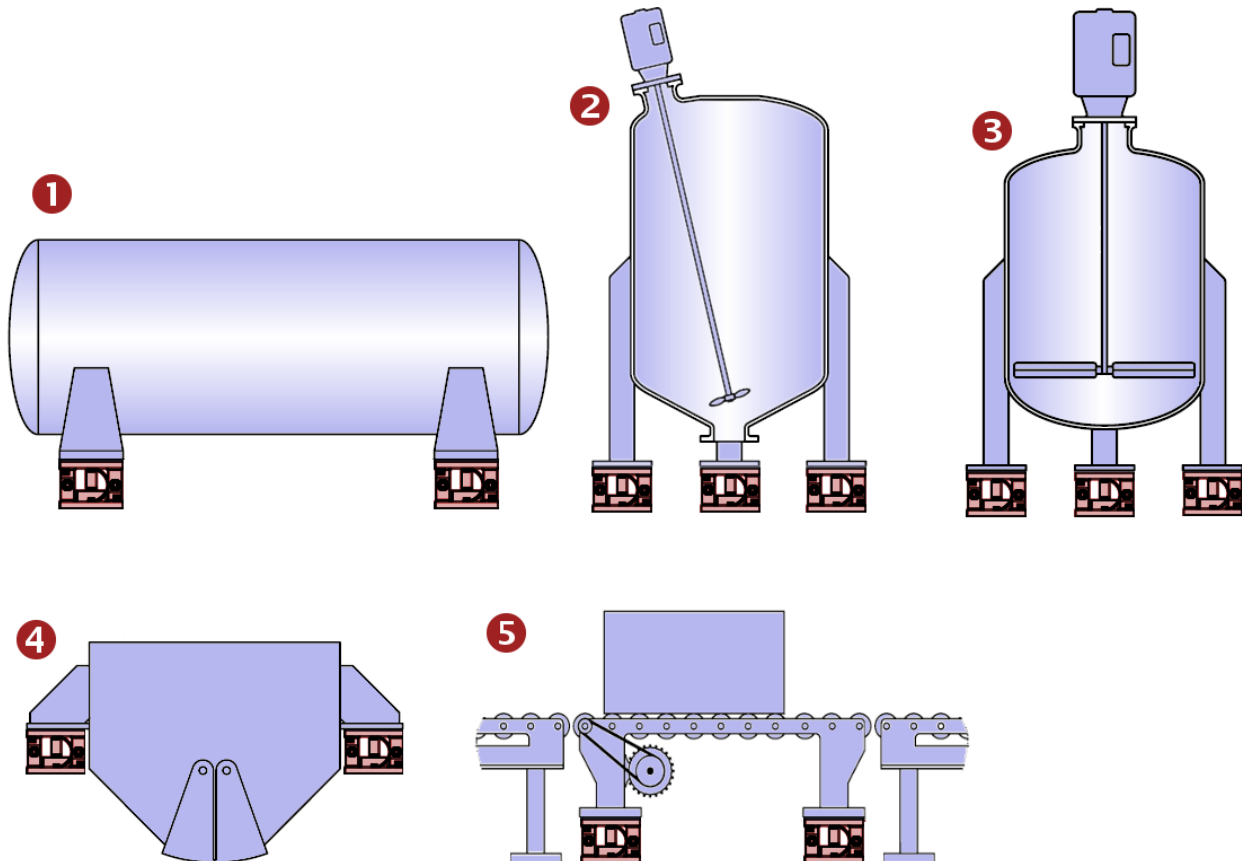

- **Static vessel ①:** A static horizontal or vertical vessel, without a mixer, does not require restraint devices. Restraint devices are not required when the only operation is filling and emptying the vessel.
- **Vessel, with low speed mixing ②:** Some vessels are equipped with a low power mixer for mixing liquid. Restraint devices are not required, even if the mixing takes place at the same time as the weighing.
- **Vessel with mixing, static weighing ③:** This type of scales is sometimes subjected to dynamic forces, but not during the weighing operation. As the mixer does not affect the weighing, restraint devices are not required.
- **Dosing machine ④:** Some dosing machines incorporate vibrators for easier emptying. Opening and closing the doors can cause additional shocks. As long as these forces do not happen during the weighing operation, restraint devices are not required on a dosing machine.
- **Conveyor, low speed ⑤:** In low speed (usually high capacity) conveyor weighing applications where the stabilisation time is not critical, the structure is left to recover after any horizontal impacts. If the platform is occasionally subjected to severe shocks, mounting kits with integrated side stops are recommended.

For these applications, the mounting kit will be chosen according to:

- The weighing capacity
- The required accuracy
- Any potential vibrations
- Any occasional side shocks.

► Refer to §3 which provides a description and a guide for choosing the mounting kits.

5.11.2. Applications that require restraint devices

A stabilising device removes significant lateral forces, which are part of the normal operation of the system. This device generally consists of a tie rod allowing vertical movement and preventing any horizontal movement.

The system is fully stabilised horizontally by combining the restraint devices from all the mounting kits installed. To ensure an effective stabilisation, the mounting kits must be laid out correctly.



- **Do not confuse the lateral stabilisation device and the lateral stop device:**

- A restraint device prevents side forces that appear during normal operation.
- A side stop is a safety device which should only be used to prevent occasional strains or shocks.

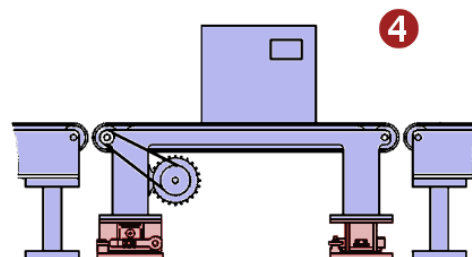
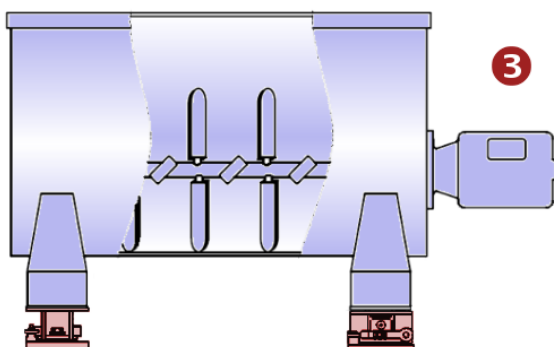
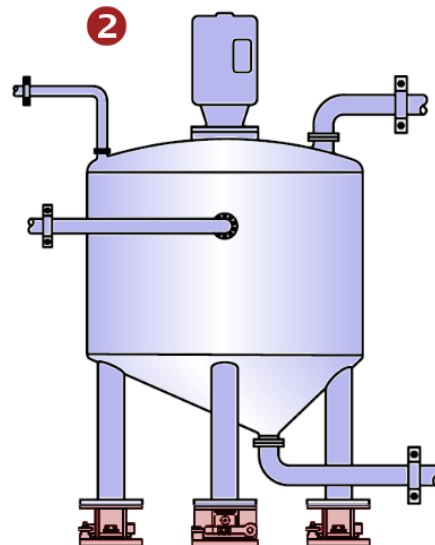
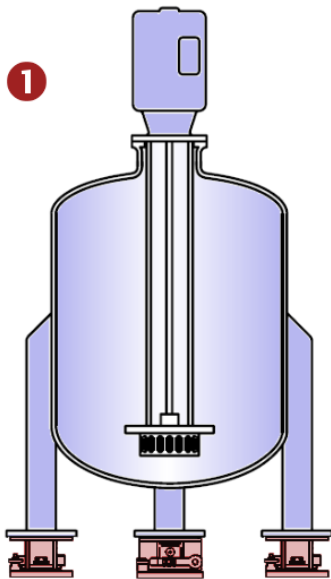

- **Vessel with high power mixer ①**: High power mixers disperse, emulsify or homogenise liquids, pastes, powders or solids. These mixers generally operate at high speed and can create high vibrations and oscillations. Restraint devices are recommended for such an application.
- **Vessel with a mixer and rigid pipes ②**: When a vessel is equipped with a powerful mixer and rigid pipes, the tank oscillation can cause pipe fatigue failures. Restraint devices help maintain the vessel static and prevent damage to the pipes.
- **Horizontal mixer ③**: In this system, the mixer rotates in a horizontal vessel. It is used to mix ingredients to produce a paste. Strong vibrations are too expected for such operations, so the use of restraint devices is highly recommended.
- **High speed conveyor ④**: High speed and high capacity conveyors are uncommon. If stabilisation time is critical for this type of application, restraint devices should be used to hold the conveyor in place.

For these applications, the mounting kit will be chosen according to:

- The weighing capacity
- The required accuracy

▶ Refer to §3 which provides a description and a guide for choosing the mounting kits.

5.11.3. Additional safety when in compression

Even though mounting kits provide protection against lateral or uplift forces, additional stabilisation systems may be required in case of high exposure to wind, in seismic areas, or for installations with powerful mixers.

These additional devices must be designed to allow a vertical degree of freedom for weighing, while eliminating lateral forces.

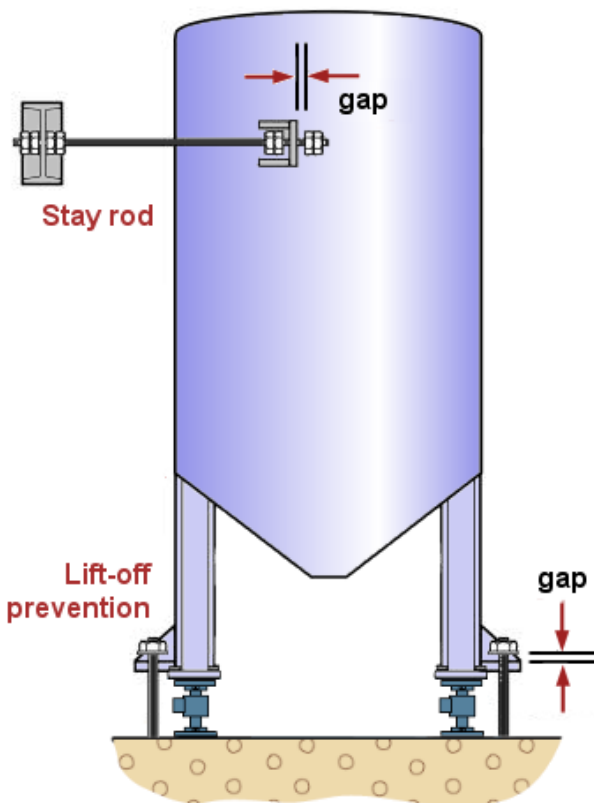

- Stay rods are used to limit a tank's horizontal movement so that it will not tip or rotate. They should be positioned at or above the centre of gravity of the tank when full.



- A lift-off prevention system must be installed if the mounting kit does not include such a safety device.

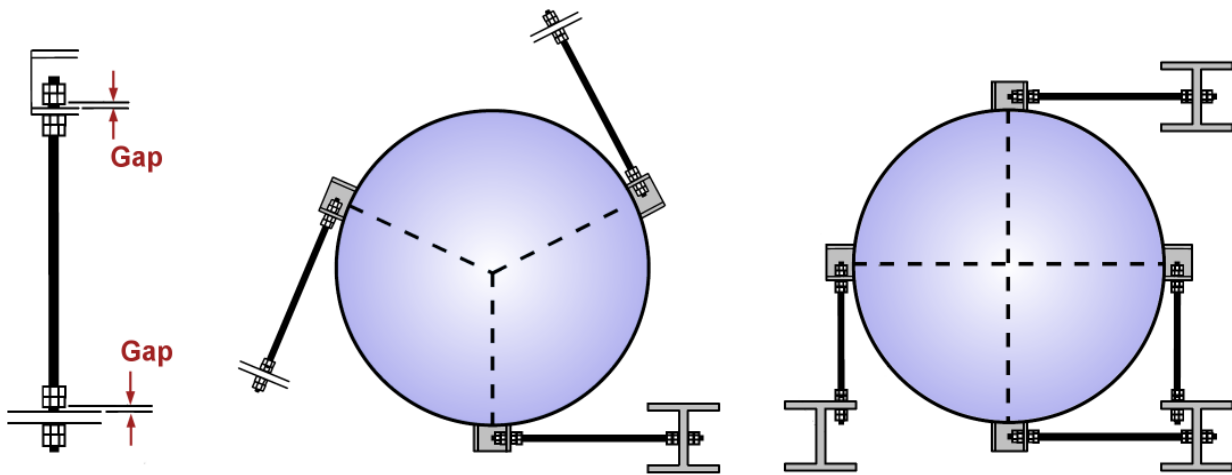

- Note that the rods are tangential to the tank, with a gap between the nuts on the end of the rods and the brackets on the tank. This allows the rods to restrain the tank while allowing for minor thermal expansion.

5.11.4. Additional safety in tension

Any tank that is suspended by S-type load cells should have a secondary safety restraint system. The safety rods must be robust enough to support a full tank in the event one of the load cells fails. For most applications, installing a vertical safety rod near each S-type load cell is sufficient.

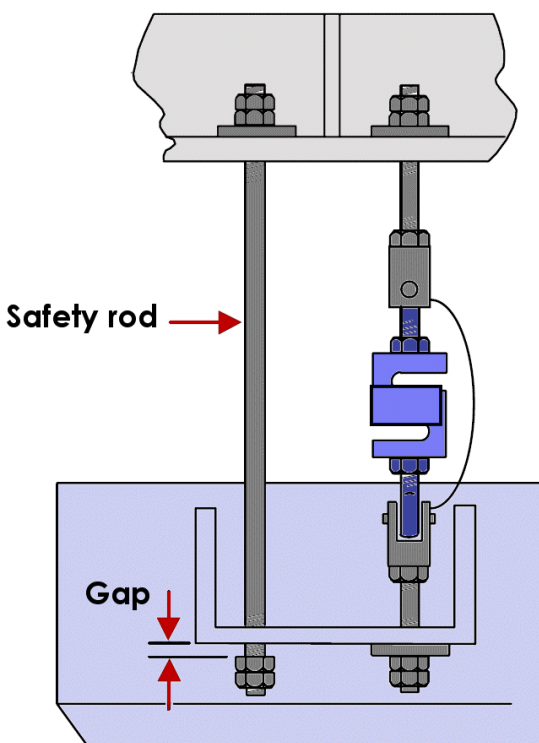

- Adjust each safety rod by letting the rod protrude so as not to influence the measurements.
- The safety rods must be strong enough to support the full tank in the event of a failure of the main suspension system.
- Horizontal safety rods or stops can be used to prevent swaying.



- Any tank suspended in tension must be equipped with a secondary holding system.

5.12. Pivoted weighing system

In certain applications, only half of the vessel can be weighed with the other half being supported on a dummy load cell or a flexible beam acting as pivots.

Although a welded pivoted weighing system is cheaper, a mounting kit equipped with a dummy load cell gives the option of adding a working load cell at a later date if greater accuracy is required.

Pivoted weighing systems can provide a cost-effective method but with a low accuracy ($\pm 1\%$) detection system.

Pivoted weighing systems are especially suited to vessels containing liquids or gas. They are not suitable for weighing solids, powders or granules because the horizontal displacement of the centre of gravity causes inaccuracies.

The vessel or the silo must be symmetrical about a vertical axis along which the centre of gravity (G) increases/decreases as the tank or silo is filled or emptied. Consistent load distribution is essential for a proper operation of the pivoted weighing system

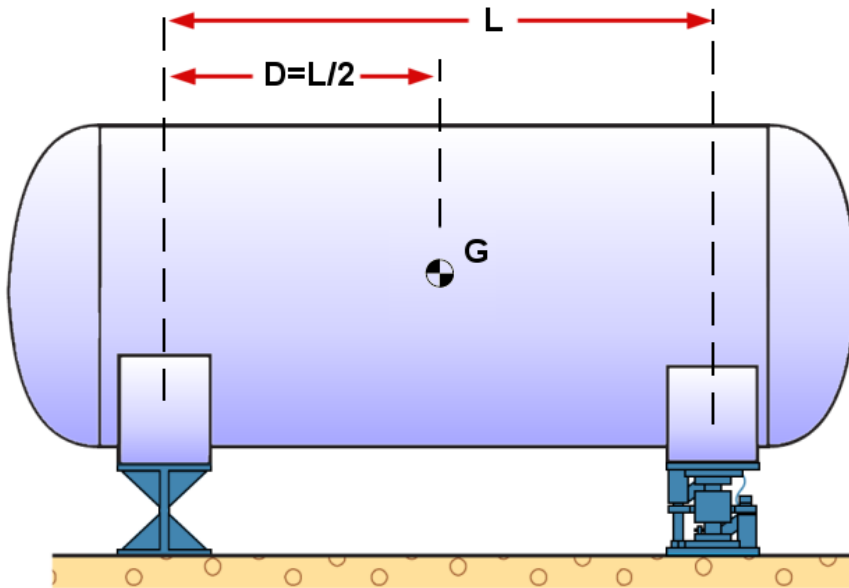

- In fact, it is not the weight, but the force that is measured by the load cell. This force can be calculated using the following formula:

$$F_{LC} = \frac{D \times F_{Total}}{L}$$



- The vessel must be symmetrical about the vertical line passing through the centre of gravity of the contents.
- The vessel is located indoors and is not subjected to wind.
- The vessel should be resting on only three or four support points
- The distance between the actual load cell and the dummy load cell (L) must be as great as possible.

5.13. Piping connections

A tank supported by load cells will warp when a load is applied. This is due to the inherent deformation of the load cells and the structure under the load, the latter usually being the greatest.

Each time the pipes are connected to a vessel (direct and permanent connection), this produces unwanted vertical forces. Using incorrectly installed or poorly designed piping may cause weighing errors by supporting some of the weight that should be applied to the load cells.

Force exerted by a pipe

When the vessel is full, it moves downwards due to the deflection (Δh) from the sensor and the structure.

A force is exerted by the pipe on the vessel and influences the measurements. The more flexible the pipe, the less force is applied to the vessel.

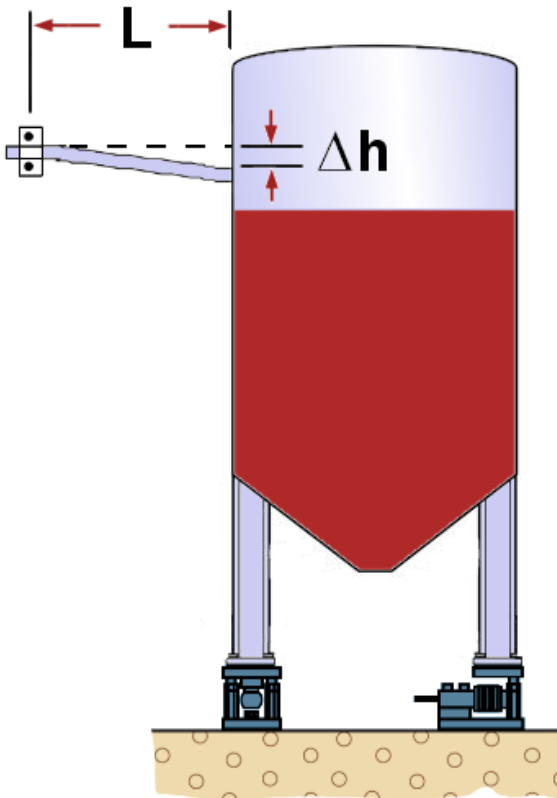

The force exerted by the pipe is equal to:

$$F = \frac{0,6 \times (D^4 - d^4) \times \Delta h \times E}{L^3}$$

With:

- **D** = Outside diameter of pipe (mm)
- **d** = Inside diameter of pipe (mm)
- **E** = Young's modulus (for steel: 210,000 N/mm², for copper: E= 110,000 N/mm²)

The pipes must be able to reduce unwanted forces on the vessel. This is even more important that accuracy requirements are important.

Here you will find general guidelines for designing a piping system:

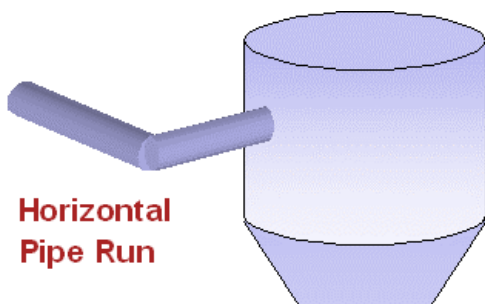

- Do not connect vertical pipes to a vessel. The loaded tank tends to deform and subside, the pipe prevents this within the limits of its rigidity.
- Route all the pipes horizontally from the tank. A 90 degree elbow in the horizontal direction will make the pipe more flexible.
- Use a pipe with the smallest possible diameter and the smallest possible thickness. This will make the pipe more flexible.

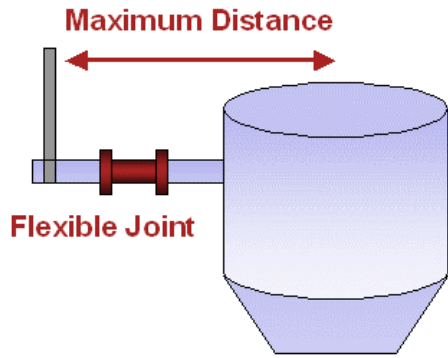

- Reduce the number of pipes connected to the overdraft.
- Use flexible pipes and connections whenever possible.
- Locate the first rigid support for the piping as far away from the tank as possible. This will make the pipe more flexible.

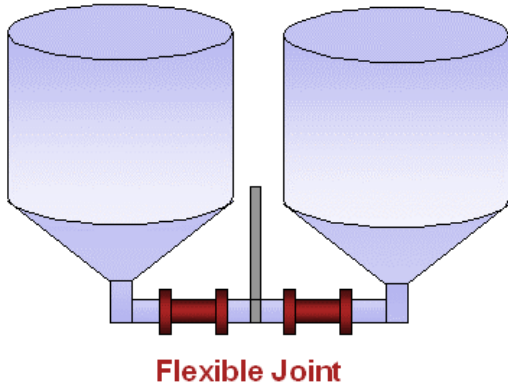

- When a single discharge pipe is used by adjacent tanks, design the system so that the discharge piping from each tank is supported independently and does not interact with the other tank.

- Do not attach the piping to a mezzanine, a floor or a structure that moves independently from the tank.
- Instead, attach the piping to the tank's support structure so that the piping moves along with the tank.

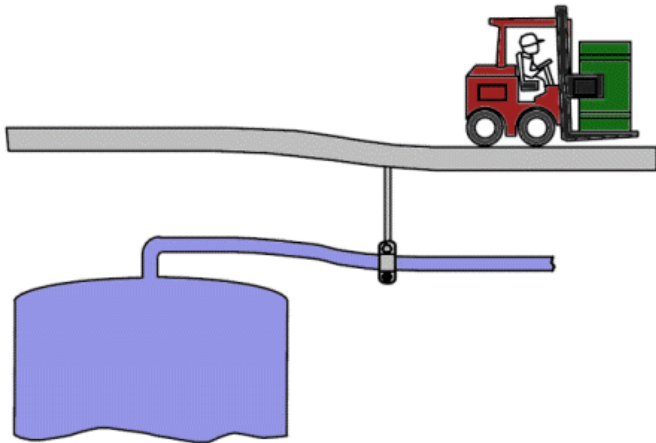

Not Recommended

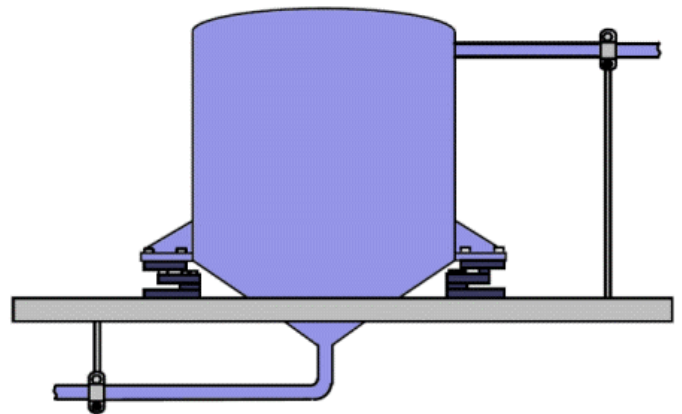

Recommended

5.14. Environmental factors

Because environmental factors can affect the accuracy and safety of a weighing system, these must be taken into account during the design stage.

5.14.1. Wind or seismic activity

Wind and seismic forces can have a great effect on outdoor weighing system. Upward, downward, and shear forces are exerted on load cells.

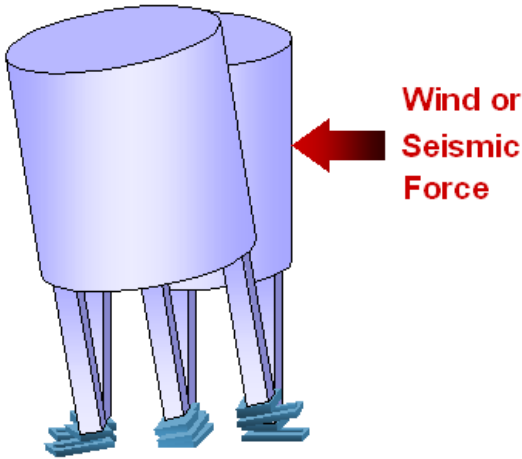

Wind effect

Because of the effect of wind on a weighing system, it is important to select the right load cell capacity and determine the best mount to use in outdoor application.

These effects are complex and depend on factors such as the degree of exposure, local topography and maximum wind speed.



- Take into account the additional loads when selecting the load cells
- Mechanical restraints can be applied to maintain the scales' position.

Beaufort scale specifying wind speed

| | Beaufort | Km/h | m/s |
|--------------------|----------|---------|-------|
| Strong normal wind | 5 | 30-40 | 8-11 |
| Strong wind | 6 | 40-50 | 11-14 |
| Very strong wind | 7 | 50-60 | 14-17 |
| Stormy | 8 | 60-72 | 17-20 |
| Storm | 9 | 72-85 | 20-24 |
| Heavy storm | 10 | 85-100 | 24-28 |
| Very heavy storm | 11 | 100-115 | 28-32 |
| Hurricane | 12 | 115-180 | 32-50 |

Wind striking an exposed tank or silo will generate a side force which causes an overturning moment and a smaller vertical force.

- **When the silo is empty:** The wind force may be sufficiently strong to overturn the structure.
- **When the silo is full:** The combination of the overturning force reaction, and the total weight of the silo, may generate an overloading on the load cells.

Wind force

The installation is affected by horizontal forces, acting in the direction of the wind.

These forces can be calculated, in N by: $F = \frac{1}{2} \times \delta \times C \times A \times V^2$

Where:

- δ : air density (1,293 kg/m³),
- **C**: Drag coefficient (0.8 for an upright circle cylinder)
- **A**: Exposed cross section (m²)
- **V**: Wind speed (m/s)

Example

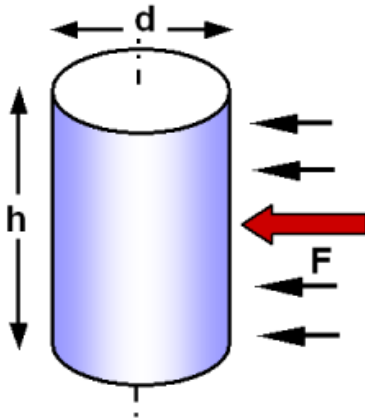

Specifications

- V = 30 m/s
- h = 10 m
- d = 3 m
- A = h x d

$$F = 0,5 \times 1,293 \times 0,8 \times h \times d \times V^2$$

$$F = 13960 \text{ N}$$

The wind force generates an overturning moment, which will be counterbalanced by a reactive moment of the load cells.

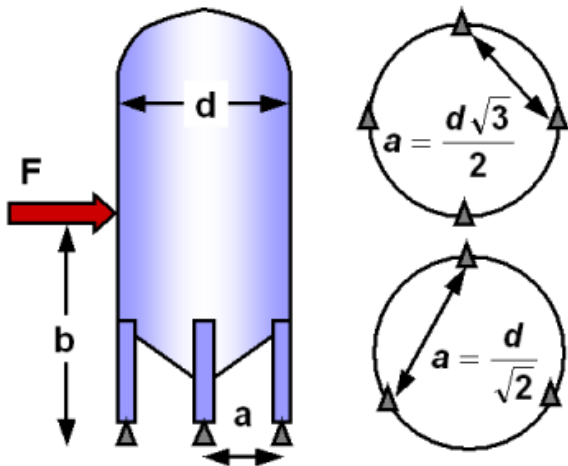

F_{ov} : Overturning force caused by the wind

$$F_{ov} = \frac{F \times b}{a}$$

Where:

- **F**: Overturning force caused by wind force
- **a**: Distance between load cells
- **b**: height at which the wind force acts

Using the previously calculated wind force of **13960 N** and a value for **b** equal to half the height of the silo:

$$F_{ov} = \frac{13960 \times 5}{3} = 23300 \text{ N} = 2380 \text{ kg}$$

Conclusion

- In case of an empty silo, lift-off protection should be considered if the dead weight of the tank on each load cell is below **2380 kg**.
- In case of a full silo, **2380 kg** must be added to the calculated load cell capacity.

5.14.2. Shock loading

A dynamic load on the weighing system can be accidental or inherent to its operation. This must be taken into account during the design phase.

It is caused by a sudden change in the weight on the weighing system caused by a load being dropped or an object placed on the system. This can happen while the weighing system is being loaded, for example when using a grapple, an electromagnet or a lifting device.

If there is a risk, use higher capacity load cells to accommodate for potential large shocks and use shock absorbing material for load damping.

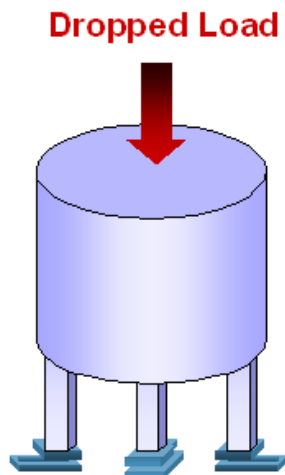

Shock forces caused by dropped weights:

$$W_1 \times \left(1 + \sqrt{\frac{(1 + 2H) \times K}{W_1 + W_2}} \right) + W_2$$

Where:

- **W₁** = Weight of the object being dropped (kg)
- **W₂** = Dead weight (kg)
- **K** = Load cell spring rate: Rated capacity divided by load cell deflection at rated capacity (kg/m).
- **H** = Height from which the object has been dropped

Use of shock absorbers

Using mounting kits with integrated elastomeric pads or the inclusion of shock absorbers between the upper plates of the mounting kit helps attenuate the dynamic load transmitted to the load cells by increasing the deformation of the structure under the load.

5.14.3. Vibration

Caused by the surrounding environment or a mixer, vibrations induce electrical noise on the load cell's signal.

Some SCAIME electronics (e.g. eNod) incorporate powerful filtering systems that can eliminate the effects of vibrations. However, it is important to implement systems to reduce internal or external vibrations that the electronics cannot eliminate.

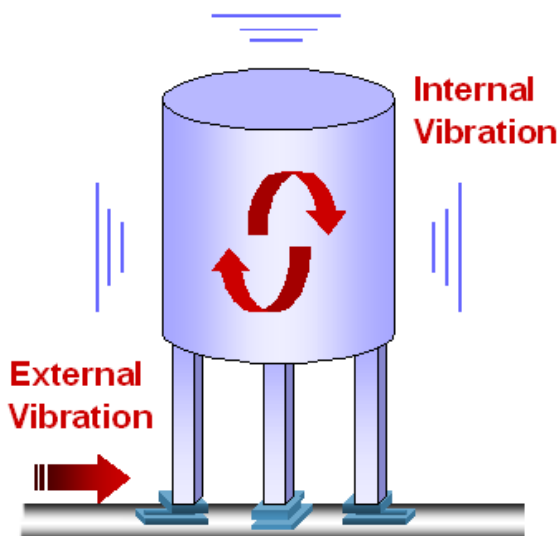

- **External vibrations:** Vibrations from foundations or the environment. Locating the source of vibrations and eliminating it is recommended. You may also separate the structure from the load cells supports.
- **Internal vibrations:** Vibrations are usually caused by the action of mixing liquids. You can reduce swaying by incorporating baffles in the tank. If a mixer is permanently attached to the tank, you may consider adding shock absorbers.

5.14.4. Temperature effects

Temperature can influence a load cell due to expansion and contraction of the media.

As the tank expands and contracts, mechanical connections may occur between the weighing system and adjacent structures. In this case, the vertical displacement is disturbed and the measurement is affected. It is important to include, in the design, the space required between tanks for dilatation.

If the weighing system is rigidly connected to the load cells, its expansion can generate unwanted lateral forces on the load cells. The load cells should not be bolted directly to the structure, but mounting kits that allow expansion should be used (see §3).

Temperature variations can cause the expansion of the pipes, and consequently axial forces on the tank. These forces can affect accuracy if the pipes are connected vertically to the tank.

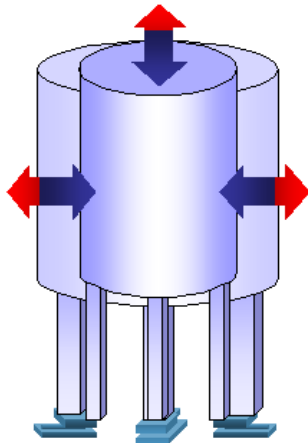

Changes in the length of an object according to the change in temperature:

$$\Delta L = a \times L \times \Delta T$$

With:

- ΔL = Variation of the length in mm
- a = Coefficient of linear expansion in mm/mm °C
- L = Original length in mm
- ΔT = Temperature variation in °C

Examples of linear expansion coefficients:

- Aluminium: 23.0×10^{-6}
- 304 stainless steel: 17.3×10^{-6}
- 17-4PH stainless steel: 10.8×10^{-6}
- Soft steel: 11.7×10^{-6}

5.14.5. Moisture, corrosion and debris

Preventative maintenance

Preventive maintenance is often overlooked by load cell users. However, a few checks and simple maintenance tasks can greatly increase the lifespan of load cells.

Moisture and corrosive substances can physically damage the load cells and cause short circuits in the electronics. Debris accumulated on the load cells will cause measurement errors by limiting the system's vertical mechanical movement.

- Provide adequate drainage away from the load cells.
- Regularly clean accumulated debris. Keep cables clean and in good condition.
- Protect load cells and cables from corrosive materials.
- If required by the environment, regularly clean the load cells to prevent any chemical corrosion

Corrosion resistance

Load cell resistance to corrosion is a complex subject, mainly due to the wide variety of configurations. As such, the standard corrosion charts are the main reference for load cells. The appendix of this guide includes the standard corrosion charter, for use only as an indication.

In addition to this indication, the following influencing factors must be taken into account:

- Condition of the surface of the load cell
- Welding quality and thickness for sealed load cells
- Stress levels on the load cells

The environment also plays an important role in the load cell behaviour. Salt water, for example, has very different corrosive effects depending on the circumstances. Stainless steel in standing salt water will be subject to corrosion and regular cleaning will be necessary to prevent rapid degradation of the load cell.

Unfortunately, the term “stainless steel” is synonymous with “No corrosion, no problem and no maintenance”. Although stainless steel provides optimum protection in many environments, other factors should be taken into account.

Therefore, for some applications, applying a coat of paint or marine grease after installing the load cells and the mounting kits, may be an effective method of controlling corrosion.

5.14.6. Weighing in an hygienic environment

Agri-food professionals have to meet more and more food safety requirements, especially with regards to the construction of packaging machines such as weight fillers or portioning machine.

For these applications, SCAIME provides single point load cells whose hygienic design is certified by the EHEDG (European Hygienic Engineering and Design Group), an association promoting the hygienic design of equipment in the food industry.



EHEDG Certification

- **EL type:** Equipment cleaned with liquids
- **CLASS I AUX:** Open equipment (Surfaces are on the outside of the equipment) which is cleaned without dismantling

These load cells, made from stainless steel and hermetically sealed, offer a level of protection IP68 and IP69K ensuring their continuous operation in the most severe environment.

With an hygienic design, cleaning is much easier. A piece of equipment with no horizontal flat surface or sharp angles ensuring that the Cleaning In Place (CIP) or Sterilisation In Place (SIP) process will remove all debris from microorganisms.

5.14.7. Lightning and surge protection

Electrical surges can cause permanent damage to the load cells. Electrical surges may be caused by lightning, large electrical machines or welding.

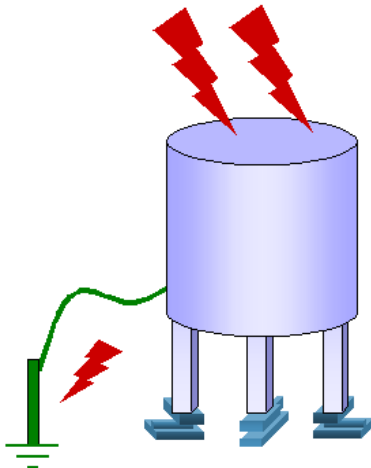

- Verify the integrity of any existing grounding systems.
- Use a single-point grounding system and surge protection devices.
- Do not carry out electric welding near load cells.



- **Every load cell should be shunted by a stranded copper cable to prevent welding currents from flowing through the load cell.**

5.15. Calibration

When a weighing system is installed, it must be calibrated so that the readings on the indicator accurately reflect the amount of weight placed on the scale.

Calibration error

Incorrect calibration of the weighing equipment will cause errors in the readings. In the event of a calibration error, the relationship between weight and load is linear but incorrect.

This could be due to an error during theoretical calibration or to the use of a reference weight that was too low for a physical calibration process.

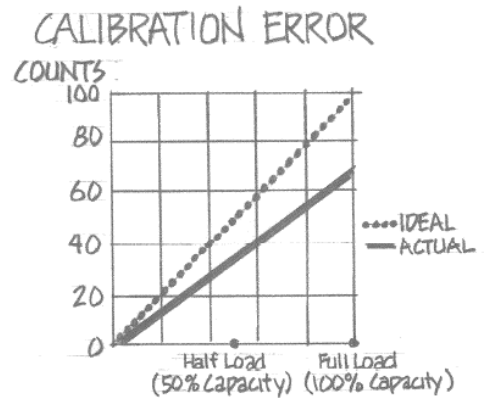

There are several methods used for calibration that will be described below:

5.15.1. Physical calibration with test weights

The most accurate reliable way to calibrate a set of scales is by using test weights.

This method is generally used for weighing low capacity platforms or vessels, because of the difficulty of handling and positioning large weights.

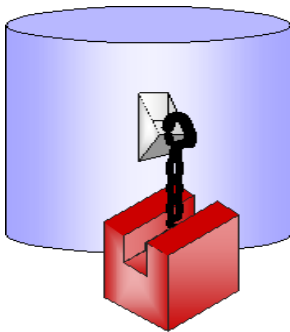

Install brackets, evenly spaced around the tank to hang the test weights.



- A calibration using test weights should be carried out up to the maximum capacity of the system with test weights.
- If this is not possible, it is not advisable to carry out the calibration with less than 20% of the maximum capacity in test weights.

Procedure for a multiple load cell tank

When weighing a tank with several load cells, each load cell's signal output should be measured to ensure an even load distribution.

- Hang a test weight near one load cell mount and take a reading. Move the test weight to a second load cell, take a reading. Repeat for each installed load cell.
- Shims should be placed under each load cell mounts until the signal output from each individual load cell varies less than 25% at each signal.

This mainly applies to vessels with 4 or more load cells. Vessels with 3 load cells that have been levelled should naturally have an automatic weight distribution.

Physical calibration process

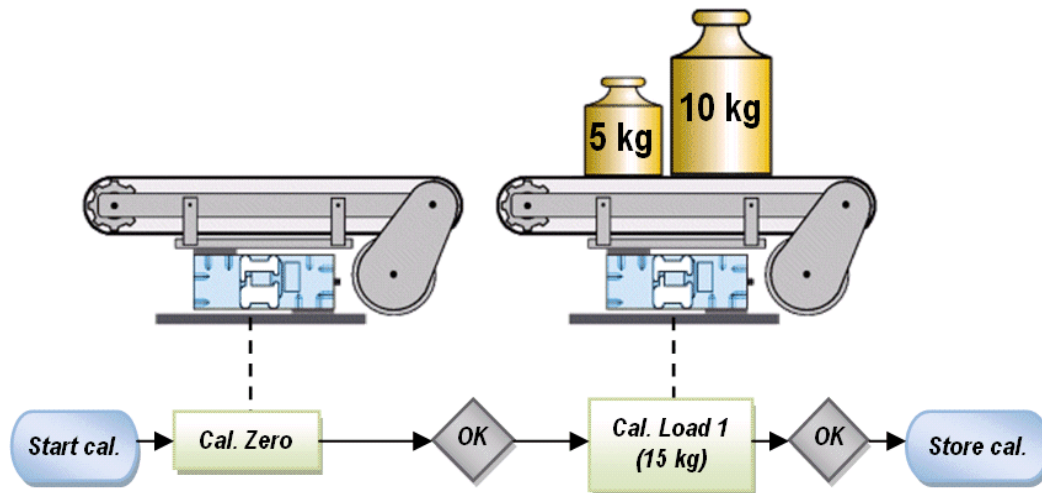

- Empty the scale (or vessel), ensure there is no interference with the vessel.
- Set the Zero of the weighing instrument.
- Hang the calibration load (test weights) on the scale.
- Calibrate the weighing instrument, so that it reads the same as the weight applied.
- Remove the test weights and check for a return to zero.
- If you have enough test weights, add the weights to the vessel one by one and check the linearity of the system. If the system is not linear, check for mechanical interference.

5.15.2. Physical calibration with material transfer

For large tanks, it is generally physically impossible to hang test weights. In this case, you can use another measuring instrument to measure the weight of a set amount of material, and then use this material as the test weight.

The most common methods use a volumetric flow meter to measure water flowing into the vessel, or use another scale.

- This method is usually a simple way to calibrate a weighing vessel, but the accuracy of the weighing vessel will only ever be as good as the accuracy of the measuring instrument.
- The calibration process is the same than physical calibration. Test weights are replaced by known amount of material used as calibration loads.

Calibration with material transfer

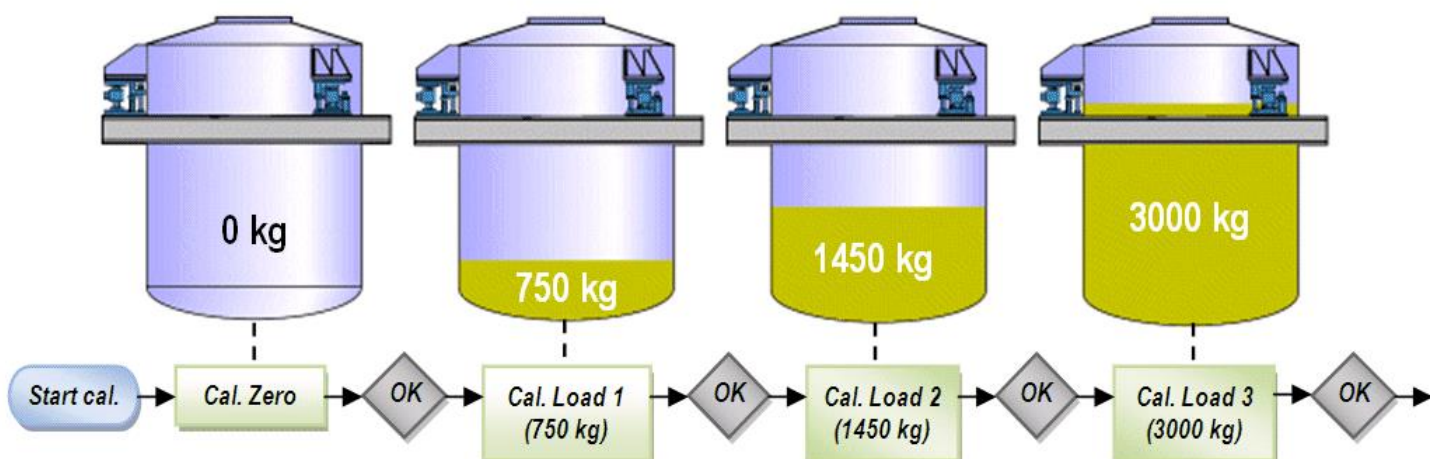

5.15.3. Load cell simulation

A third calibration method consists in replacing the load cells with an electronic device simulating a load cell. The simulator sends out a signal equal to the signal the load cell should produce.

The main issue with the load cell simulator is that it does not take into account the effect of variations caused by misalignments or mechanical connections to the weighing system.

When the load cell simulator is connected, the calibration process is similar to the physical calibration:

- With the simulator adjusted to no output, set the indicator to zero.
- Adjust the simulator to full output (i.e. a signal equal to that which all the load cells would produce at their rated capacity).
- Adjust the indicator to show the total capacity of all load cells in the system.
- Connect the load cell input to the indicator.
- Set the indicator to read zero for the empty weight of the tank.

5.15.4. Theoretical calibration

When the previous methods cannot be used, a final calibration method can be used if the weighing terminal provides this functionality.

This method consists in entering the load cells parameters inside the weighing terminal and carry out a theoretical calibration.

Theoretical calibration process

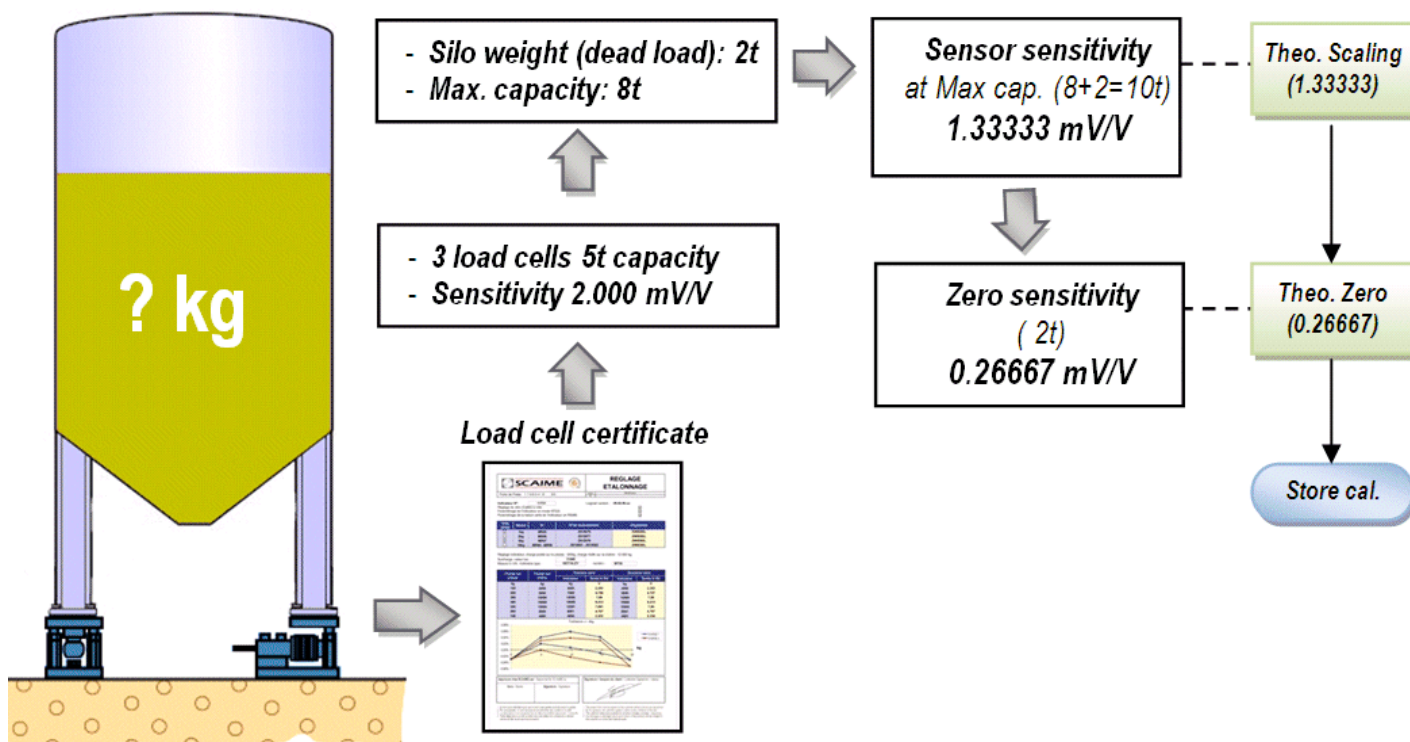

- On the certificate provided with the load cells, read the load cell sensitivity (in mV/V).
- Calculate the theoretical load cell output signal when no load is applied to the scales (the silo is empty): this is the load cell "zero" sensitivity in mV/V.
- Calculate the theoretical load cell output signal when a maximum load is applied to the scales (the silo is full): this is the load at maximum sensitivity in mV/V.
- Enter these 2 values in the weighing terminal and carry out the theoretical calibration.

6. Electrical wiring

6.1. General considerations

Load cells with a strain gage measuring system can be connected to carrier-frequency measuring amplifiers or DC measuring amplifiers designed for strain gauge measurement systems.



- **Electric and magnetic fields often cause interference voltages that are coupled into the measurement circuit.**

- Only use shielded, low capacity measurement cables (measurement cables provided by SCAIME meet these requirements).
- Do not route these measurement cables along the excitation and control lines. If this is not possible, protect the measurement cable (e.g. using steel-sheathed pipes).
- Avoid the leakage fields of the transformers, motors and contactors.

6.2. 4-wire/6-wire load cells

The Wheatstone bridge measurement technology requires a minimum of four wires to be connected to the conditioning electronics.

For load cells with 4-wire connection, the cable is part of the load cell's temperature compensation system. The load cell is calibrated and compensated with its connection cable.

Some load cells use a 6-wire connection. They use two additional wires on the excitation diagonal to control the voltage across the load cell terminals. If the resistance of the cable changes due to temperature variations or if the cable length is different, the conditioning system internally compensates for the voltage drop by adjusting the voltage sent to the load cell.

The advantage of the 6-wire connection is that you can use very long cables (up to several hundred meters) without affecting the sensitivity of the load cell. Any changes to the wire resistance caused by temperature variations will not affect the readings. This is particularly convenient when the cable temperature and the load cell temperature are different.

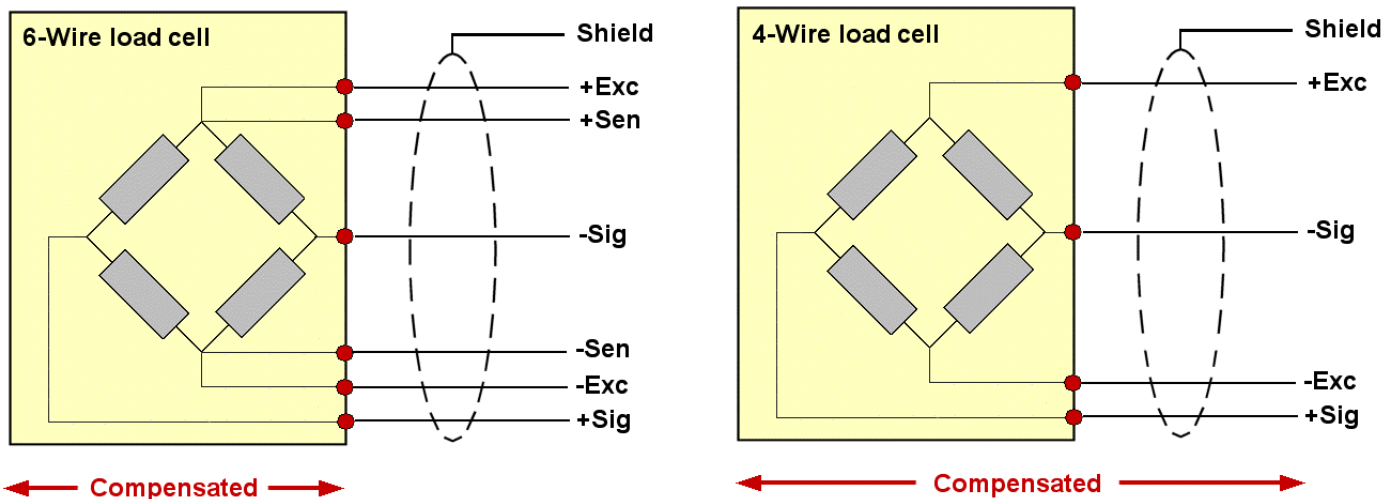

- **The cable of a 6-wire load cell can be shortened.**
- **The cable of a 4-wire load cell cannot be shortened.**

6.3. Multiple load cells connection

In multiple load cell weighing systems, load cells can be wired in parallel by joining the load cell cable core ends of the same colour. For this, SCAIME provides ALCJB junction boxes. The output signal is then the average of the individual output signals.



- An overload on an individual load cell cannot then be detected from the output signal.

When multiple load cells are connected together in parallel, the current required to supply these load cells can exceed the maximum output of the indicator.

To calculate the required current output for a given installation, use the following formula:

$$\text{Required current} = V_{EXC} \times \left(\frac{1}{R_{LC}} \right) \times N_{LC}$$

With:

- V_{EXC} : Excitation voltage
- R_{LC} : Load cell input resistance
- N_{LC} : Number of load cells



- Check the indicator is able to provide the electrical supply to the load cells.

Sometimes, the output from each individual load cell needs to be trimmed to avoid varying readings due to the position of the load. These differences can be caused by:

- Difference in load cells output resistance.
- Uneven load distribution.

Trimming can be done by adjusting variable resistors (P1...Pn) placed into the excitation paths of the ALCJB.

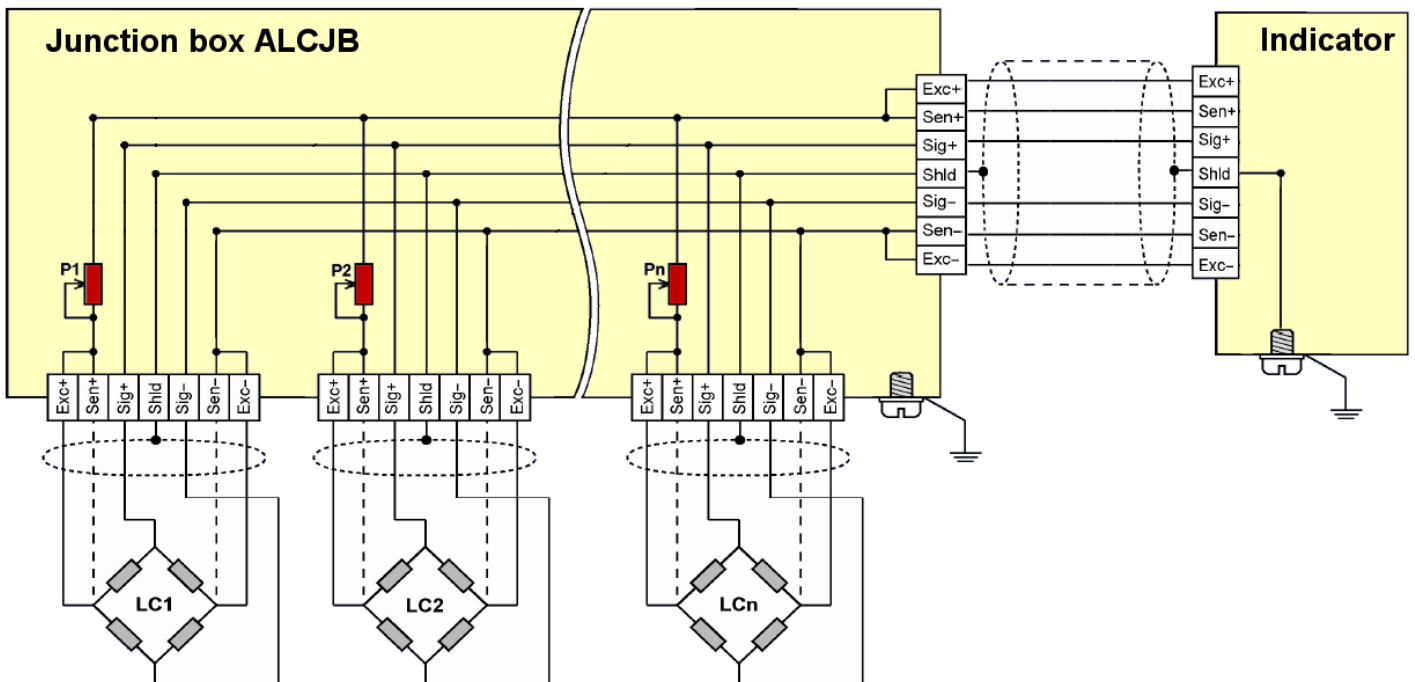

6.4. Cable extension

Extension cables must be shielded and of low capacitance. We recommend using SCAIME cables, which satisfy these requirements.

With cable extensions, a good connection with minimum contact resistance and good insulation is essential.

When using the 6-wire circuit, the effects of resistance changes in the extension cable are compensated.

If you extend the cable using the four-wire circuit, the sensitivity deviation can be removed by adjusting the amplifier. However, temperature effects can only be compensated when operating with the six-wire circuit.

6.5. Grounding and shielding

6.5.1. Grounding

Proper grounding and shielding can be critical to the successful operation of load cells which are generating extremely low level signals ($<5\mu\text{V}/\text{scale division}$).

Load cell cables are provided with a braided shield which protects the cables from electrostatic interference when properly used. This shield could be floating (not connected at the load cell body) or connected to the load cell body (refer to the load cell datasheet).

The load cell body and junction box are grounded via a mechanical attachment to the structure to which they are mounted.

The braided shield enclosing the load cell cables is grounded at the indicator, which is grounded through the power supply cable or its body.



- Load cell cables should be kept away from power circuits, with a minimum distance of 1m.
- Power supply cables should be crossed at right angles.

6.5.2. Load cell shielding connection

The shield protects against interference and electromagnetic fields. To ensure maximum shielding efficiency, the following are essential:

- A good connection from the shield to the ground.
- The uniformity and continuity of the shielding, especially if cable extensions are used.

- ▶ **For the best protection, the shielding should be connected on both sides when possible. The load cells are then protected against high frequency (HF) and low frequency (LF) interference.**

If the shielding is only connected on one side, it is only effective for LF interference.

Shielding not connected to the body of the load cell

In some cases, the shielding is not connected to the body of the load cell and therefore cannot be grounded.

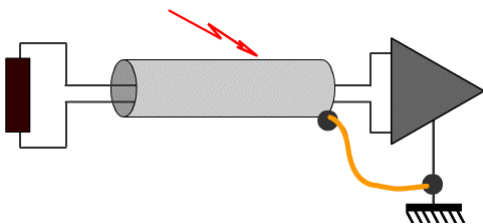

- In this case, the shielding must imperatively be grounded via the conditioning system.
- Protection against LF interferences is then guaranteed.

Shielding connected to the body of the load cell

In most load cells, the shielding is connected to the load cell body. The load cell, cable and conditioner assembly make up a Faraday cage effective against parasites.

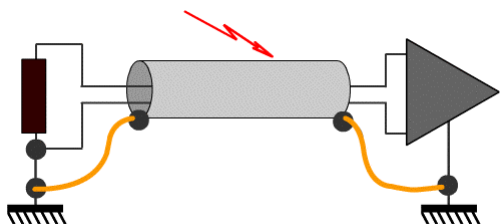

- In this case, the shielding will be connected on the conditioner side if equipotential grounding is correct.
- Protection against LF and HF interferences is then guaranteed.

Issues with equipotential grounding

Measurement cables and their shielding have a small section with a fairly high impedance, so they cannot be used for equipotential grounding.

If the equipotentiality is incorrect, the shielding loops the ground and a interference current is generated by it. The shielding, instead of protecting the measurement cables, becomes a generator of interference causing measurement instability.

- ▶ **An equipotential connection must be established as soon as possible.**

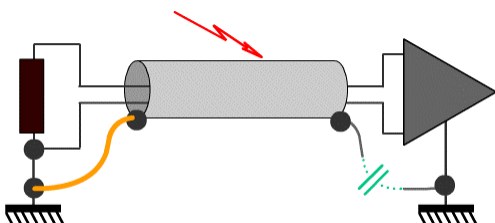

- If equipotential grounding is not possible, loop currents are avoided by grounding the shielding with a capacitor connected in series.
- Most electronic compounds (eNod for example) incorporate this capacitor as standard.
- Protection against LF and HF interferences is then guaranteed.

Finally,

- If equipotential grounding is not possible,
- If the conditioner is not equipped with a capacitor to connect to ground
- If a capacitor cannot be added to the shield connection to ground

Then the unconnected shielding will be left on the conditioner side.

7. Load cell troubleshooting

Load cells might be damaged because of overloading (shocks), heavy electrical surges (lightning strikes), chemical or moisture ingress, mishandling (dropping, lifting on cable, etc.), vibration or internal component malfunction.

As a direct consequence, the system may drift (zero), provide unstable or erroneous readings, or not provide any at all.

7.1. In general

Carefully check the system integrity before evaluating the load cells:

- Check for force shunts (might be caused by dirt, friction or mechanical misalignment).
- Check cable connections to junction box and indicator.

Visually inspect the load cells before performing the tests as described on the following pages. Pay attention to signs of corrosion and the integrity of the cable.

7.2. Load cell test procedure

Load cell characteristics can be found on the control sheet supplied with each load cell.

The following test equipment is required to properly assess a load cell:

- A digital volt- and ohmmeter with a measuring accuracy of ± 0.1 mV and ± 0.5 Ω , to measure the zero balance and integrity of the Wheatstone bridge.
- A low voltage megohmmeter, capable of reading 1000 M Ω at 50 volts, to measure the insulation resistance.

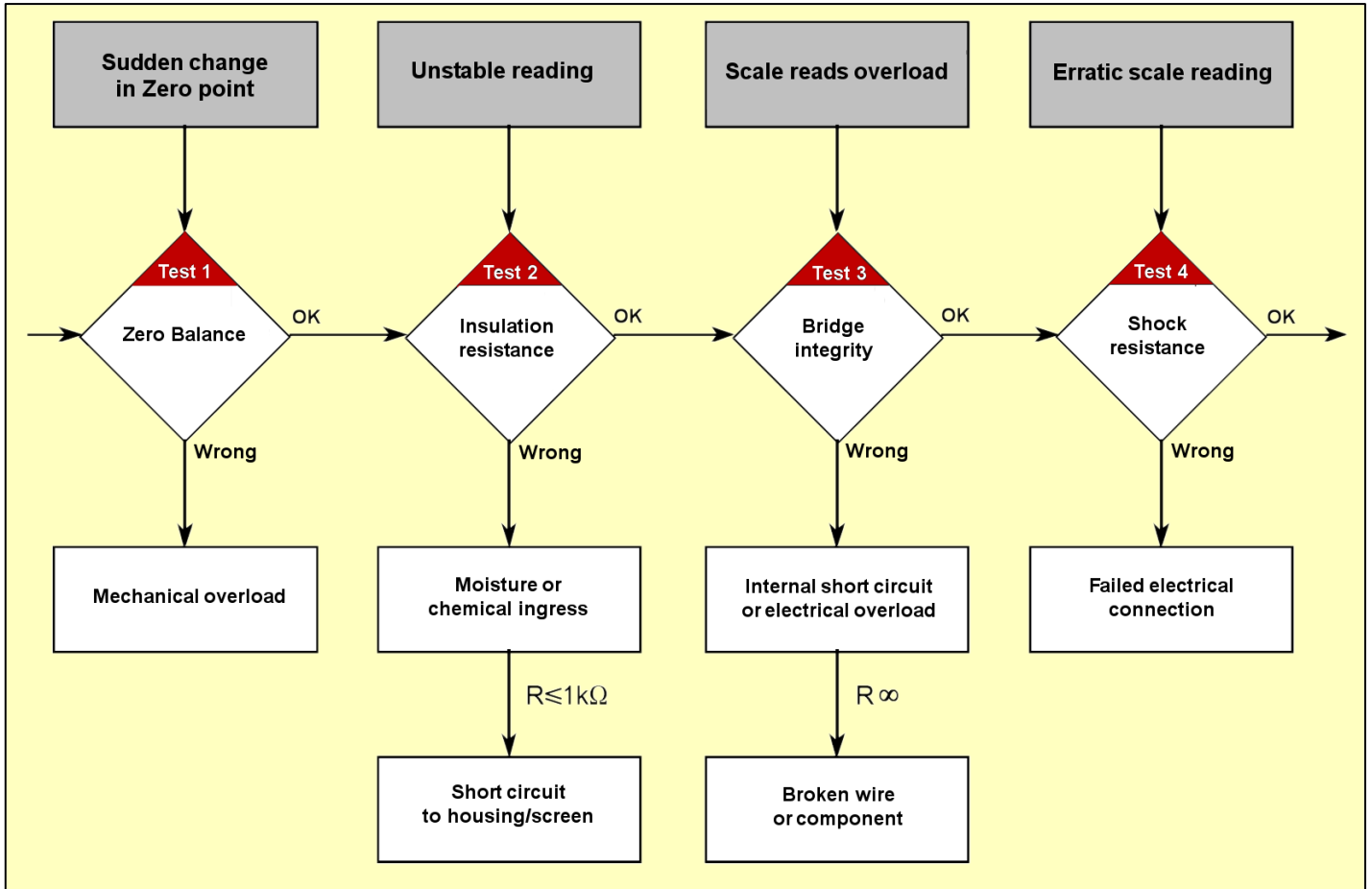

▲ Load cell test diagram

7.2.1. Test 1: Zero Balance

The Zero Balance is defined as the load cell signal in a "no-load" situation.

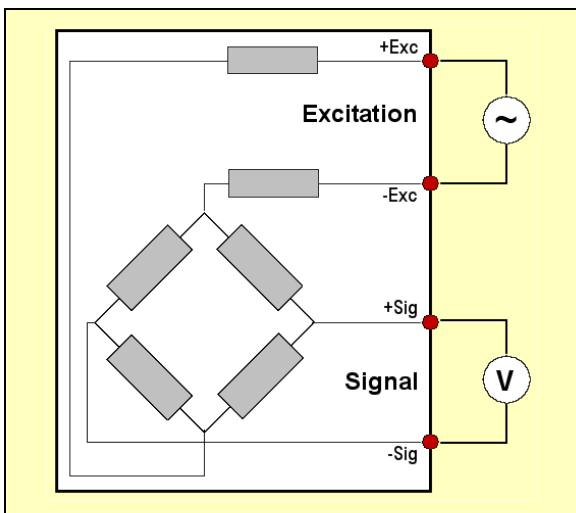

- Connect the load cell to a stable power supply (weighing indicator) with an excitation voltage of at least 5 volts.
- Disconnect any other load cell for multiple load cell systems.
- Measure the voltage across the load cell's signal leads with a voltmeter and divide this value by the input or excitation voltage to obtain the Zero Balance in mV/V.
- The measured value must be within the load cell zero balance limits.

Analysis:

Changes in Zero Balance occur if the load cell has been permanently deformed by overloading or shocks.

Load cells that experience progressive zero output changes per time period are most likely undergoing a change in the strain gauge resistance because of moisture ingress. In this case the insulation resistance and/or the bridge integrity will also be compromised.

7.2.2. Test 2: Insulation resistance

The insulation resistance is measured between the load cell circuit and sensor body or cable shield.

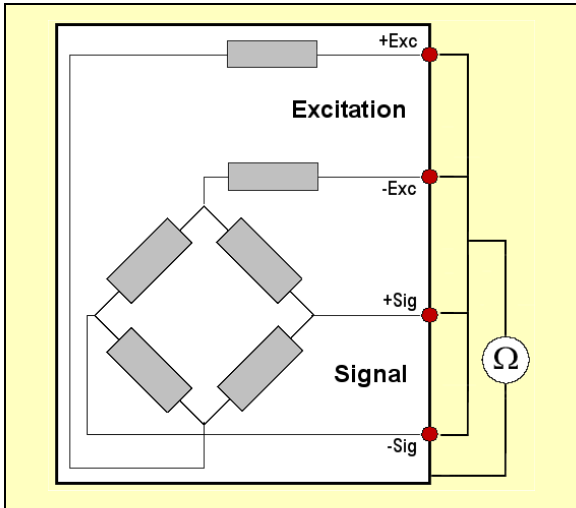

- Disconnect the load cell from the junction box or indicator and connect all excitation, signal and sense (if applicable) cables together.
- Measure the insulation resistance with a low voltage megohmmeter between these four or six connected wires and the load cell body.
- Repeat the measurement between these wires and the cable shield.
- Finally measure the insulation resistance between the load cell body and cable shield.

Analysis:

The insulation resistance must be greater than 1000 MΩ. A lower value indicates electrical loss, which is often caused by moisture or chemical contamination inside the load cell.

Extremely low values (< 1kΩ) indicate a short circuit rather than moisture ingress. Electrical leakage often causes load cell or indicator instability. Stability might vary with temperature.



- **Some megohmmeters can supply 500 V and could damage the load cell. Do not supply the load cell with a voltage greater than 50 V.**

7.2.3. Test 3: Wheatstone bridge integrity

The bridge integrity is verified by measuring the bridge input and output resistance.

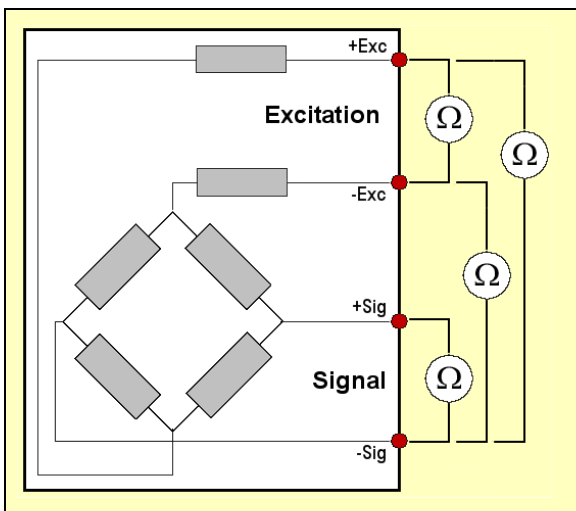

- Disconnect the load cell from the junction box or measuring device.
- Measure the input and output resistance with an ohmmeter across each pair of cables (excitation and signal).
- Compare the input and output resistance with the datasheet.
- Measure and compare the resistance from -Sig to -Exc, and -Sig to +Exc to get the bridge balance. The difference between both values should be $\leq 1\%$

Analysis:

Changes in bridge resistance or bridge balance are most often caused by a broken wire, an electrical component failure or internal short circuit.

This might result from electrical surges (lightning or welding), physical damage from shock, vibration, excessive temperature, or from production inconsistencies.

7.2.4. Test 4: Shock resistance

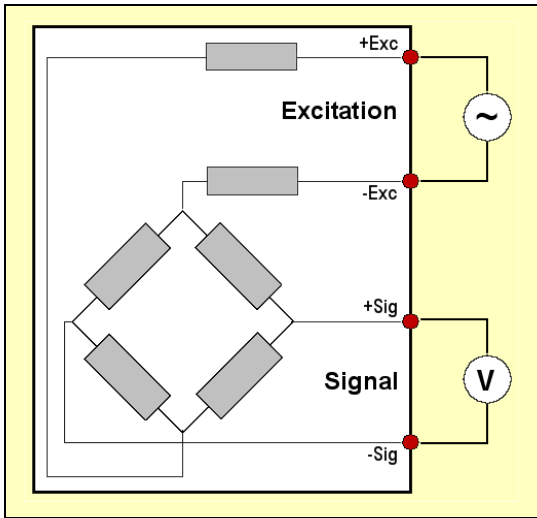

- Connect the load cell to a stable power supply.
- Disconnect any other load cell for multiple load cell systems.
- Connect a voltmeter to the signal output leads.
- Lightly rap on the load cell support with a small mallet to mildly shock it. Take extreme care not to overload low capacity load cells while testing their shock resistance.
- Read the voltmeter during the test. The readings should not become erratic, should remain reasonably stable and return to their original zero readings.

Analysis:

Erratic readings may indicate a failed electrical connection or a damaged glue layer between the strain gauge and the load cell body as a result of an electrical transient.

8. Appendices

8.1. *DOs & DON'Ts of load cells*

8.1.1. DOs

REMINDER: although load cells may look extremely robust, they contain delicate sensing devices and can be very easily damaged by misuse rendering the unit unusable.

1. **Select** the right load cell for the application in terms of type and environmental compatibility.
2. **Choose** the right capacity.
3. **Consider** the required accuracy class.
4. **Consider** the environmental effects on accuracy (wind, friction, thermal expansion, wiring or piping attachment).
5. **Design** adequate over/under load protection as well as protection from other mechanical damage (e.g. physical abuse, rodent problems...).
6. **Use** dummy load cells prior to installation.
7. **Beware** of shock loadings. These can be very high and, even if they are short, can easily cause permanent damage.
8. **Store** and **handle** load cells carefully prior to and during installation.
9. **Use** high quality bolts with the recommended torque.
10. **Check** the surface to which a load cell is to be attached is flat and that the surface finish is appropriate.
11. **Check** the cable colour code for the load cells prior to connection.
12. **Use** good quality connecting terminals/junction boxes.
13. **Inspect** load cells and weigh system regularly especially after extreme weather conditions (electrical storms, flooding, seismic activity, etc.) and also before and after the seasons.
14. **Check** for corrosion damage to the load cell and mounting hardware.

8.1.2. Don'ts

1. **Don't let** the load cells operate above their rated capacity.
2. **Don't drop** a load cell onto the floor.
3. **Don't hammer** a load cell into place. Shock loads can permanently damage some units.
4. **Don't use** the load cell as a mechanical connection.
5. **Don't forget** to protect the load cell cable.
6. **Don't carry out** electric welding near the load cells.
7. **Don't ever carry** load cells by their cable.
8. **Don't force** bolts or other threaded assemblies.
9. **Don't cut** load cell cables unless necessary, performance may be affected.
10. **Don't allow** the load cell to be the electrical link between the ground and the metal weighing structure. Prefer using adequate bonding straps and isolators.
11. **Don't exceed** the specified input voltage rating when energising a load cell.
12. **Don't exceed** the recommended operating temperature range.
13. **Don't allow** the build-up of water/debris around the load cells.

8.2. Protection according to EN60529

IP 1st digit
Protection against solid objects

| | | |
|----------|--|---|
| 0 | | No protection |
| 1 | | Protected against solid objects up to 50 mm and accidental touch by hand |
| 2 | | Protection against solid objects (> 12.5 mm) and accidental touch with fingers |
| 3 | | Protection against solid objects (> 2.5 mm) and accidental contact (tools) |
| 4 | | Protection against solid objects (> 50 mm) and accidental contact (tools + small wires) |
| 5 | | Protection against dust. Dust ingress should not cause interferences. |
| 6 | | Complete protection against dust. |

IP 2nd digit
Protection against liquids

| | | |
|----------|--|---|
| 0 | | No protection |
| 1 | | Protection against vertically falling drops of water |
| 2 | | Protection against falling drops of water up to a 15° angle from the vertical. |
| 3 | | Protection against rainwater up to a 60° angle from the vertical |
| 4 | | Protection against sprayed water in all directions |
| 5 | | Protection against low pressure water jets in all directions |
| 6 | | Protection against strong water jets in all directions from a fire hose |
| 7 | | Protection against temporary immersion, up to a depth of 1 m |
| 8 | | Protection against long periods of immersion (30 min), at a depth greater than 1 m. |

8.3. Protection class IP69K according to DIN40050

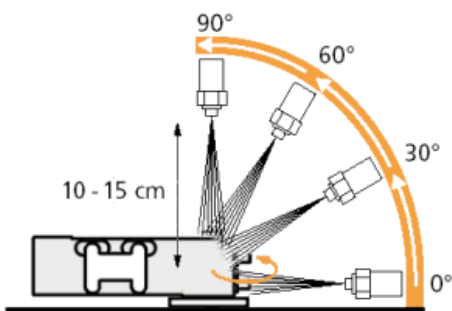

IP69K test according to DIN 40050/part 9

The goal of the test is to simulate pressure cleaning conditions. In the test, the load cell is exposed to a water jet at a pressure of 100 bars at a temperature of 80 °C. The duration of each cleaning cycle is 30 s. The test is carried out with a spray nozzle located at defined angles and at a distance of 10 - 15 cm from the load cell.

8.4. Corrosion resistance chart

Corrosion resistance data in this publication is only indicative. This information can be considered as a basis for a recommendation but not as a guarantee. Materials should be tested in actual use to determine their suitability for a particular purpose.

| | Con (%) | T (°C) | 304 stainless steel |
|--------------------------------|---------|---------|---------------------|
| H ₂ SO ₄ | 0.05 | 60 | ●●● |
| | 1 | 20 | ●● |
| | 2 | 60 | ●● |
| | 5 | 35 | ● |
| | 10 | 20 | ●● |
| | 20 | 20 | ●● |
| | 20 | 35 | ● |
| | 25 | 25 | ●● |
| | 20 | 20 | ● |
| >40 | >20 | - | |
| HCl | 0.2 | 20 | ●● |
| | 0.2 | 50 | ● |
| | 1 | 20 | ● |
| | 2 | 20 | ●● |
| | >2 | >20 | - |
| HNO ₃ | 50 | 60 | ●●● |
| | 60 | 20 | ●●● |
| | 60 | Boiling | ●● |
| | 65 | Boiling | ● |
| | >90 | Boiling | - |
| H ₃ PO ₄ | 30 | 102 | ●●● |
| | 50 | 108 | ●● |
| | 50 | Boiling | ● |
| | 60 | | ●●● |
| | 60 | Boiling | - |
| | 80 | | ●● |
| | 80 | Boiling | - |
| CH ₃ -COOH | 10 | | ●●● |
| | 10 | Boiling | ●● |
| | 80 | | ●●● |
| | 80 | Boiling | ● |

| | Con (%) | T (°C) | 304 stainless steel |
|---|---------|-----------|---------------------|
| HCOOH | 10 | 20 | ●● |
| | 10 | Boiling | ● |
| | 40 | 65 | ● |
| H ₂ CO ₃ | <100 | < Boiling | ●●● |
| | 25 | Boiling | ●●● |
| NaOH | 30 | Boiling | ● |
| | 34 | 20 | ●●● |
| | 34 | Boiling | ● |
| | 50 | 20 | ●● |
| | 60 | Boiling | - |
| Ca(OH) ₂ | <100 | < Boiling | ●●● |
| NH ₄ OH | <100 | < Boiling | ●●● |
| NaNO ₃ | <100 | < Boiling | ●●● |
| Na ₂ CO ₃ | <100 | 20 | ●●● |
| | 100 | 820 | - |
| NaCl | <100 | 30 | ●●● |
| | 100 | >30 | ● |
| NH ₄ Cl | 10 | 20 | ●●● |
| | 10 | Boiling | ●● |
| | 25 | 20 | ●● |
| | 25 | Boiling | ● |
| (NH ₄) ₂ SO ₄ | 5 | 20 | ●●● |
| | 10 | 20 | ●● |
| | 10 | Boiling | ● |
| FeCl ₂ | 10 | 25 | ●●● |
| FeCl ₃ | 1 | 20 | ● |
| | 5 | 20 | - |
| K ₂ CO ₃ | 30 | 65 | ●●● |
| HBr/HF | | | - |
| Acetone | 100 | < Boiling | ●●● |
| Ether | 100 | < boiling | ●●● |

●●● Unaffected

●● Slightly affected

● Severely affected

- Unusable

8.5. Safety instructions

In cases where a failure may cause injury to persons or damage to equipment, the user must take appropriate safety measures (such as fall protection, overload protection, etc.). A safe and trouble-free operation of the load cells requires proper transportation, correct storage, assembly and mounting as well as careful operation and maintenance.

It is essential to comply with the relevant accident prevention regulations. More specifically, you should take into account the limit loads quoted in the specifications.

▶ Use in accordance with the regulations

SCAIME load cells have been designed for weighing applications. Use for any other purpose shall be deemed to be not in accordance with regulations.

To ensure safe operation, the load cells should only be used as described in this manual. Appropriate legal and safety regulations regarding the application concerned during use will also be complied with. The same applies to the use of accessories.

Load cells can be used as machine components (e.g. for tank weighing). Please note in these cases that, in order to achieve high sensitivity, load cells have not been designed with the safety factors normally applied in machine design.

The load cell is not a safety element within the meaning of its use in accordance with regulations.

▶ Qualified staff

These load cells are only to be installed by qualified personnel strictly in accordance with the specifications and with the safety rules and regulations which follow. Appropriate legal safety regulations regarding the application concerned will also be complied with. The same applies to the use of accessories.

Qualified personnel means persons entrusted with the installation, fitting, commissioning and operation of the product which has the appropriate qualifications for their function.

▶ Environmental conditions

In the context of your application, please note that acids and all materials which release chlorides will attack all the layers of the stainless steel and any welding seams. This may corrode the load cell which can lead to other failures.

▶ Prohibited modifications

The load cells must not be modified from a design or safety engineering point of view except with our express agreement. Any modification shall exclude all liability on our part for any damage resulting therefrom.

▶ Option: Explosion-proof version

Users must comply with all relevant regulations during installation.

The installation conditions listed in the certificate of conformity and/or type examination certificate must be complied with.

Using load cells

You may download our documents on

WWW.SCAIME.COM



SCAIME SAS

Technosite Altéa
294, Rue Georges Charpak
74100 Juvigny – France

T: +33 (0)4 50 87 78 64

F: +33 (0)4 50 87 78 42

info@scaime.com

www.scaime.com

